

# Z-Wave Curtain Motor Controller

70130012



**Important:** Read All Instructions Prior to Installation

## Function introduction

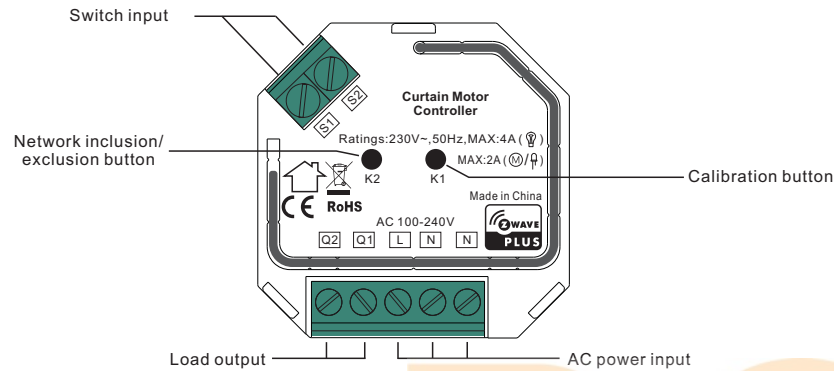

## Product Data

Z-Wave Frequency	868.42 MHz (EU)/908.42 MHz (US)/921.42 MHz (ANZ)
Input Voltage	AC 100-240V
Output Voltage	AC 100-240V
Max. Load Current	Resistive loads: 4A Capacitive/inductive loads: 2A
Operating temperature	0 to 40°C
Relative humidity	8% to 80%
Dimensions	45.5x45x20.3mm

## Safety & Warnings

- DO NOT install with power applied to device.
- DO NOT expose the device to moisture.

## Quick Start

How to install:

- Step 1: power on the Z-Wave curtain motor controller.
- Step 2: activate inclusion mode on your Z-Wave controller.
- Step 3: activate inclusion mode of the curtain motor controller by triple press the network inclusion/exclusion button. The curtain motor controller will be included to Z-Wave network.

## Product Description

The curtain motor controller is a universal, Z-Wave Plus V2 compatible, electric motor controller. The device allows for controlling motors of roller blinds and venetian blinds, which are single phase AC powered. The curtain motor controller allows for precise positioning of a roller blind or venetian blind slats. Precise

positioning is available for the motors equipped with mechanic and electronic end switches. The device also allows for controlling on/off of lights. The module may be controlled wirelessly, through the Z-Wave network primary controller, or through the switch keys connected to it. In addition, the curtain motor controller is equipped with Power Metering and over current protection.

The curtain motor controller can be included and operated in any Z-Wave network with other Z-Wave certified devices from other manufacturers and/or other applications. All non-battery operated nodes within the network will act as repeaters regardless of vendor to increase reliability of the network.

If the user's gateway also supports smartstart, add the device by scanning the QR code, Smartstart allows users to quickly add devices to the gateway by scanning the device's QR code. After adding the device by scanning QR code, wait for a while or reset power of the device, the device will be added to the gateway automatically. Please find the QR code on the casing of the device.

The encryption mode that the curtain motor controller supports is S2 Unauthenticated. When the device is being included into a Z-Wave network, you can use your primary controller/gateway to enable encryption mode or disable encryption. (The primary controller/gateway shall support encryption mode configuration). The curtain motor controller supports OTA and can update firmware wirelessly.

## Main Features:

- Compatible with any Z-Wave or Z-Wave+ Controller,
- Controlled by Sunricher EasyHome or any other Z-Wave controller,
- Advanced microprocessor control
- Active element: electromagnetic, micro-gap relay switch
- The device may be operated by momentary or toggle switches, and by dedicated roller blind control switches
- Connected motor's current and historical power consumption measured
- Over current protection
- To be installed in wall switch boxes of dimensions allowing for installation, conforming to provisions of applicable regulations
- The curtain motor controller supports OTA and can update firmware wirelessly

## Installation Guide

Please read carefully the enclosed user manual before installation of the curtain motor controller, in order to ensure an error-free functioning.

**ATTENTION:** Prior to the assembly of the product, the voltage network has to be switched OFF and ensured against re-switching.

## Inclusion (adding to a Z-Wave network)

1. Set primary controller/gateway into inclusion mode (Please refer to your primary controller's manual on how to turn your controller into inclusion).
2. Power on the curtain motor controller and set it into inclusion mode. There are two methods to set the roller shutter into inclusion mode:
  - 1) Triple press the network inclusion/exclusion button, it will set the curtain motor controller into inclusion mode. 30 seconds timeout if there is no reply from the Z-Wave primary controller, repeat the operation.
  - 2) When the value of configuration parameter 8 is set as 1, triple press the switch connected to S1, it will set the curtain motor controller into inclusion mode. 30 seconds timeout if there is no reply from the Z-Wave primary controller, repeat the operation.
3. The curtain motor controller will be added to the Z-Wave network.

## Exclusion (removing from a Z-Wave network)

1. Set the primary controller/gateway into exclusion mode (Please refer to your primary controllers manual on how to set your controller into exclusion).
2. Power on the curtain motor controller and set it into exclusion mode. There are two methods to set the curtain

motor controller into exclusion mode:

- 1) Triple press the network inclusion/exclusion button, it will set the curtain motor controller into exclusion mode. 30 seconds timeout if there is no reply from the Z-Wave primary controller, repeat the operation.
- 2) When the value of configuration parameter 8 is set as 1, triple press the switch connected to S1, it will set the curtain motor controller into exclusion mode. 30 seconds timeout if there is no reply from the Z-Wave primary controller, repeat the operation.
3. The curtain motor controller will be removed from the Z-Wave network.

#### Factory Reset

Press and hold down network inclusion/exclusion button for over 10 seconds, the curtain motor controller will be reset to factory defaults.

#### Configure Parameter 3 to Set Working Mode

1. When parameter 3 value is configured as 0, light mode: either S1 or S2 can control both Q1 and Q2, short pressing or holding down will be recognized automatically. For detailed configuration please refer to configuration parameter 7.  
**Note:** when configured as light mode, rootPoint, endpoint 1 mirrors to relay 1 (Q1), endpoint 2 mirrors to relay 2 (Q2).
2. When parameter 3 value is configured as 1, shutter mode without positioning: S1 and S2 are only valid while held down. Hold down S1, relay 1 (Q1) ON, relay 2 (Q2) OFF. Hold down S2, relay 2 (Q2) ON, relay 1 (Q1) OFF. If the command is sent by a gateway, it only supports upward on, downward off, stop, it does not support positioning percentage operation.

Nodes mirror function: rootPoint, endpoint 1 with the same function: control shutter upward and downward actions. Endpoint 2 has no function.

3. When parameter 3 value is configured as 2, shutter mode with positioning: S1 and S2 are only valid while held down. Hold down S1, relay 1 (Q1) ON, relay 2 (Q2) OFF. Hold down S2, relay 2 (Q2) ON, relay 1 (Q1) OFF. When reaching any end's positioning, both relays will be OFF. If the command is sent by a gateway, it supports positioning percentage operation. When the slat function of the shutter is enabled, a valid time should be set through the parameter 13, so that the slat rotation function can be supported.

Nodes mirror function: rootPoint, endpoint 1 with the same function: control shutter upward and downward actions. Endpoint 2 controls the shutter's slat, switch multilevel set=50 means to open the slat to the maximum extent.

Note: the connected curtain motor should support position restriction function, i.e. endpoint aware.

#### Positioning Calibration

Calibration is a process during which a curtain motor controller learns the position of the limit switches and a motor characteristic. Calibration is mandatory when the working mode of the curtain motor controller is Shutter mode with positioning. Connect the controller to the motor according to wiring diagram, there are two calibration methods as follows:

1. Calibration through the calibration button, short press the button twice, calibration starts automatically, short press the button twice again, calibration will stop.
  2. Set the configuration parameter 6 value to 1, calibration starts automatically.
- Note: after installing the curtain motor, first do position restriction setting according to its user manual, i.e. top end and bottom end, then use the curtain motor controller to do positioning calibration.

#### Scene Control

Users can configure scenes using command class SCENE\_ACTUATOR\_CONF\_SET, and activate the scenes using command class SCENE\_ACTIVATION\_SET.

#### Activate Scenes Using Switch S1 S2

Users can configure configuration parameter 9 to decide whether to send scene activation command using command class CENTRAL\_SCENE\_NOTIFICATION.

The scene ID and key attribute supported by switch S1 and S2 are as follows:

Switch Number	Support Action type	Scene ID	Key Attribute
S1	Short press once	1	Key pressed once
	Short press twice	1	Key pressed twice
	Short press 3 times	1	Key pressed 3 times
	Press and hold, release	1	Key held down and released
S2	Short press once	2	Key pressed once
	Short press twice	2	Key pressed twice
	Short press 3 times	2	Key pressed 3 times
	Press and hold, release	2	Key held down and released

Default configuration of CENTRAL\_SCENE\_CONFIGURATION\_SET is Slow Refresh = 1 (send Key Held Down every 55s when the switch is pressed and held down).

#### Association

Z-Wave devices control other Z-Wave devices. The relationship between one device controlling another device is called association. In order to control a different device, the controlling device needs to maintain a list of devices that will receive controlling commands. These lists are called association groups and they are always related to certain events (e.g. button pressed). In case the event happens all devices stored in the respective association group will receive a common wireless command.

#### Association Groups:

##### Rootpoint

Association Groups	Group Name	Max Nodes	Description
Group 1	Lifeline	5	<ol style="list-style-type: none"> <li>1. When press and hold down "K2" button for 10S to reset the device, send "Device Reset Locally Notification" to associated devices of this group to report factory reset information.</li> <li>2. When over load detected, send "NOTIFICATION_REPORT" to associated devices of this group.</li> <li>3. Send METER_REPORT actively.</li> <li>4. When action of S1 and S2 is detected, send CENTRAL_SCENE_NOTIFICATION.</li> <li>5. Send SWITCH_MULTILEVEL_REPORT.</li> </ol>

##### Endpoint 1

Association Groups	Group Name	Max Nodes	Description
Group 1	Lifeline	0	SWITCH_MULTILEVEL_REPORT

## Endpoint 2

Association Groups	Group Name	Max Nodes	Description
Group 1	Lifeline	0	SWITCH_MULTILEVEL_REPORT

## Curtain Control Commands Mirror Description

	Shutter mode with positioning	Shutter mode without positioning
Basic Set (Value=0xFF)	Multilevel Switch Set (0xFF): Restore most recent(not 0) level	Multilevel Switch Set (0xFF): Open
Basic Set (Value=0x00)	Multilevel Switch Set (0x00): close	Multilevel Switch Set (0x00): Close
Basic Set (Value=0x01..0x63)	Multilevel Switch Set (0x01..0x63)	Multilevel Switch Set(0x01..0x63): Open
Basic Report (Current Value, Target Value, Duration)	Multilevel Switch Report (Current Value, Target Value, Duration)	Multilevel Switch Report (Current Value, Target Value, Duration)

Note: the Duration parameter of Multilevel Switch Set is invalid.

## Set and unset associations:

(Note: All association information will be cleared automatically once the curtain motor controller is excluded from a network.)

Set association by operating primary controller/gateway to send packets to the curtain motor controller:  
The primary controller/gateway sends packets to the curtain motor controller using "COMMAND\_CLASS\_ASSOCIATION" or "COMMAND\_CLASS\_MULTI\_CHANNEL\_ASSOCIATION".

## Node Information Frame

The Node Information Frame is the business card of a Z-Wave device. It contains information about the device type and the technical capabilities. The inclusion and exclusion of the device is confirmed by sending out a Node Information Frame. Beside this it may be needed for certain network operations to send out a Node Information Frame.

How to send out Node Information Frame:

When the curtain motor controller is set to inclusion/exclusion mode again, it will send out Node Information Frame, there are 2 kinds of operation as follows:

1. triple press the K2 button, the curtain motor controller will be set to inclusion/exclusion mode, then send out Node Information Frame.

2. When the curtain motor controller is under inclusion mode, there are two kinds of operation:

1) Triple press K2 button, the curtain motor controller will be set to inclusion mode again, and send out Node Information Frame.

2) Power off and power on the curtain motor controller, it will be set to inclusion mode automatically, and send out Node Information Frame.

## Technical Data

Wireless Range	up to 100 m outside, on average up to 40 m inside buildings
SDK	7.13.6.0
Explorer Frame Support	Yes
Device Type	Window Covering Position/Endpoint Aware
Generic Device Class	GENERIC_TYPE_SWITCH_MULTILEVEL
Specific Device Class	SPECIFIC_TYPE_CLASS_C_MOTOR_CONTROL
Role Type	Always On Slave (AOS)

Endpoint 1 device type :

GENERIC\_TYPE\_SWITCH\_MULTILEVEL/SPECIFIC\_TYPE\_CLASS\_C\_MOTOR\_CONTROL

Endpoint 2 device type:

GENERIC\_TYPE\_SWITCH\_MULTILEVEL/SPECIFIC\_TYPE\_CLASS\_C\_MOTOR\_CONTROL

Note: the rootpoint mirrored by endpoint 1 has the same function as endpoint 1.

## SUPPORTED COMMAND CLASS

### Root Device Command List

Node Info		Support S2/S0
COMMAND_CLASS_ZWAVEPLUS_INFO	V2	
COMMAND_CLASS_SECURITY	V1	
COMMAND_CLASS_SECURITY_2	V1	
COMMAND_CLASS_TRANSPORT_SERVICE	V2	
COMMAND_CLASS_SUPERVISION	V1	
COMMAND_CLASS_SWITCH_MULTILEVEL	V4	YES
COMMAND_CLASS_ASSOCIATION	V2	YES
COMMAND_CLASS_ASSOCIATION_GRP_INFO	V1	YES
COMMAND_CLASS_VERSION	V2	YES
COMMAND_CLASS_MANUFACTURER_SPECIFIC	V2	YES
COMMAND_CLASS_DEVICE_RESET_LOCALLY	V1	YES
COMMAND_CLASS_POWERLEVEL	V1	YES
COMMAND_CLASS_CONFIGURATION	V1	YES
COMMAND_CLASS_FIRMWARE_UPDATE_MD	V4	YES
COMMAND_CLASS_NOTIFICATION	V8	YES
COMMAND_CLASS_METER	V3	YES
COMMAND_CLASS_MULTI_CHANNEL	V4	YES
COMMAND_CLASS_MULTI_CHANNEL_ASSOCIATION	V3	YES
COMMAND_CLASS_SCENE_ACTIVATION	V1	YES
COMMAND_CLASS_SCENE_ACTUATOR_CONF	V1	YES
COMMAND_CLASS_CENTRAL_SCENE_V3	V3	YES
COMMAND_CLASS_WINDOW_COVERING	V1	YES

### Endpoint 1 Command List

Node Info		Support S2/S0
COMMAND_CLASS_ZWAVEPLUS_INFO	V2	
COMMAND_CLASS_SECURITY_2	V1	
COMMAND_CLASS_SECURITY	V1	
COMMAND_CLASS_SUPERVISION	V1	
COMMAND_CLASS_SWITCH_MULTILEVEL	V4	YES
COMMAND_CLASS_ASSOCIATION	V2	YES
COMMAND_CLASS_ASSOCIATION_GRP_INFO	V1	YES
COMMAND_CLASS_MULTI_CHANNEL_ASSOCIATION	V3	YES
COMMAND_CLASS_SCENE_ACTIVATION	V1	YES
COMMAND_CLASS_SCENE_ACTUATOR_CONF	V1	YES
COMMAND_CLASS_WINDOW_COVERING	V1	YES

### Endpoint 2 Command List

Node Info		Support S2/S0
COMMAND_CLASS_ZWAVEPLUS_INFO	V2	
COMMAND_CLASS_SECURITY_2	V1	
COMMAND_CLASS_SECURITY	V1	
COMMAND_CLASS_SUPERVISION	V1	
COMMAND_CLASS_SWITCH_MULTILEVEL	V4	YES
COMMAND_CLASS_ASSOCIATION	V2	YES
COMMAND_CLASS_ASSOCIATION_GRP_INFO	V1	YES
COMMAND_CLASS_MULTI_CHANNEL_ASSOCIATION	V3	YES
COMMAND_CLASS_SCENE_ACTIVATION	V1	YES
COMMAND_CLASS_SCENE_ACTUATOR_CONF	V1	YES
COMMAND_CLASS_WINDOW_COVERING	V1	YES

### Notification Report

Notification Type	Triggerring Event
NOTIFICATION_TYPE_POWER_MANAGEMENT(08)	POWER_MANAGEMENT_OVERCURRENT_DETECTED(06)

**Over Current Alarm:** When connecting to resistive load, over current value is 4.1A. When connecting to a motor or capacitive load, over current value is 2.1A. Over current LED will flash 400ms every 1 second, relays will turn off.

### Configuration Command Class

Parameter	Size	Description	Default Value
0x02(2)	1	Enable/disable the curtain motor controller to report state change percentage threshold (report only when change value at the specified percentage), if enabled, report when the value reaches both 0% and 99%. When the working mode is configured as light mode, as long as the state changes, the state change percentage threshold will be reported. SWITCH_MULTILEVEL_REPORT  0: disable to report actively 1-10: value to report, unit is one percent	5
0x03(3)	1	Working mode  0: light mode 1: Shutter mode without positioning 2: Shutter mode with positioning	2
0x04(4)	1	Enable/disable to save positioning percentage, record and save current positioning every time when the curtain moves to specified position, if the working mode is configured as light mode, record on/off state.  0x00: disable 0x01: enable	1
0x05(5)	1	Enable/disable over current protection  0: disable 1: enable, when over current detected, there are two methods to cancel alarm: 1. short press either switch button S1 or S2, the alarm will last at least 1 minute and then be cancelled. 2. re-power on the curtain motor controller	1
0x06(6)	1	Only value 1 can be written in, which means starting positioning calibration. When read, 0x01: positioning calibration completed 0x00: positioning not calibrated  This parameter is only valid when parameter 3 configured as shutter mode with positioning.	0
0x07(7)	1	When parameter 3 value configured as 0 (light mode), configuration of button S1 and S2 control.  Value=0 Short press S1 to switch ON/OFF Q1. Press and hold down S1 to switch ON Q1, then release to switch OFF Q1. Short press S2 to switch ON/OFF Q2. Press and hold down S2 to switch ON Q2, then release to switch OFF Q2.  Value=1 Short press S1 to switch ON/OFF Q1. When S1 is pressed and held down, then released, not processed. Short press S2 to switch ON/OFF Q2. When S2 pressed and held down, then released, not processed.  Value=2 Press and hold down S1 to switch ON Q1, then release to switch OFF Q1. When S1 short pressed, not processed. Press and hold down S2 to switch ON Q2, then release to switch OFF Q2. When S2 short pressed, not processed.  Value=3 Short press S1 or S2 to switch ON/OFF of both Q1 and Q2	0

		simultaneously. When S1 or S2 pressed and held down, not processed  Value=4 Press and hold down S1 to switch ON Q1 and Q2. When S1 short pressed, not processed. Press and hold down S2 to switch OFF Q1 and Q2. When S2 short pressed, not processed.	
0x08(8)	1	Enable/disable to add the device to or remove it from a Z-Wave network through button S1. Please refer to the parts of inclusion and exclusion for details.  0: enable 1: disable	1
0x09(9)	1	Enable/disable to send scene activation command CENTRAL_SCENE_NOTIFICATION_V3 when the switches S1 and S2 are pressed.  0: disable to send for action of both S1 and S2 1: enable to send for action of both S1 and S2 2: enable to send for action of only S1 3: enable to send for action of only S2	1
0x0A(10)	1	Power change absolute threshold report, unit is W  0: disable absolute threshold comparison function  1-100: value of the power change absolute threshold, if power change value is over the threshold value, report the power change value using METER_REPORT	10
0x0B(11)	1	Current change absolute threshold, unit is 0.1A  0: disable absolute threshold comparison function  1-10: value of the current change absolute threshold, if current change value is over the threshold value, report the current change value using METER_REPORT	1
0x0C(12)	1	Voltage change absolute threshold, unit is 1V  0: disable absolute threshold comparison function  1-10: value of the voltage change absolute threshold, if voltage change value is over the threshold value, report the voltage change value using METER_REPORT	2
0x0d(13)	1	Slats rotation time, unit is 0.1S  0: disable the function  5-250 (0.5S-25S): value of the slats rotation time  This parameter is only valid when parameter 3 configured as shutter mode with positioning.	0
0x0E(14)	4	Time cycle to report energy consumption value (unit is KWH), U, I, W actively  60-2678400 (31 days), value of the time cycle, unit is S.	3600 (1 hour)

## Wiring Diagram

### Notes for the diagrams:

L - terminal for live lead

N - terminal for neutral lead

S1 - terminal for switch key No. 1 (enable to set the device into inclusion/exclusion mode)

S2 - terminal for switch key No. 2



Q1 - output terminal no. 1 for electrical motor

Q2 - output terminal no. 2 for electrical motor

K1 - positioning calibration button when working mode is configured as shutter mode with positioning or venetian mode (up/down and slats rotation)

K2 - inclusion/exclusion button (used to add or remove a device from the system)

### Compatible Load Types

Supported load types		100-240V~
	Lamp and resistive loads	Max. 4A
	Inductive loads	Max. 2A
	Capacitive loads	Max. 2A

(1) Curtain Motor Connection Diagram

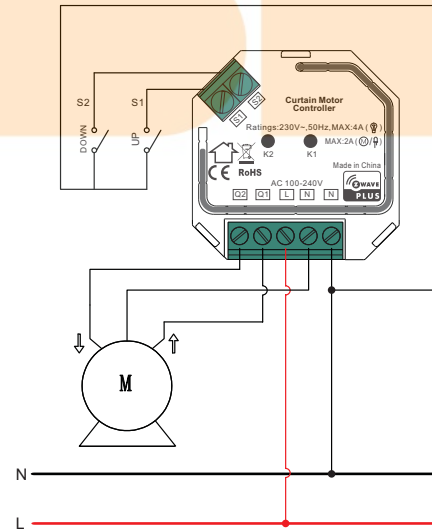

(2) Light Mode Connection Diagram

