

Z-Wave In-wall Dimmer

ROB_100-009-0



Important: Read All Instructions Prior to Installation

Function introduction

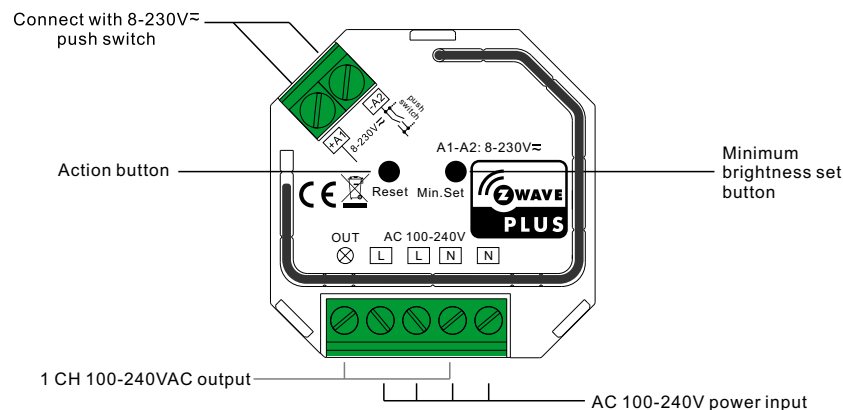

Product Data

Z-Wave Frequency	868.42 MHz (EU)/869.0 MHz (RU)/908.42 MHz (US)
Input Voltage	AC100-240V
Output Voltage	AC100-240V
Output Current	1.5A max.
Operating temperature	0 to 40°C
Relative humidity	8% to 80%
Dimensions	45.5x45x20.3mm

Compatible Load Types			
Load Symbol	Load Type	Maximum Load	Remarks
	Dimmable LED lamps	200W @ 220V	Due to variety of LED lamp designs, maximum number of LED lamps is further dependent on power factor result when connected to dimmer.
	Dimmable LED drivers	200W @ 220V	Maximum permitted number of drivers is 200W divided by driver nameplate power rating.
	Incandescent lighting, HV Halogen lamps	400W @ 220V	
	Low voltage halogen lighting with electronic transformers	200W @ 220V	

Safety & Warnings

- DO NOT install with power applied to device.
- DO NOT expose the device to moisture.

Quick Start

How to install:

- Step 1: power on the Z-Wave in-wall dimmer.
- Step 2: activate inclusion mode on your Z-Wave controller.
- Step 3: activate inclusion mode of the dimmer by triple press the action button on the dimmer. The dimmer will be included to Z-Wave network.

Product Description

The in-wall dimmer is a Z-Wave device that is used to switch ON/OFF and adjust light intensity of the connected light and can be controlled by other Z-Wave devices. The In-wall Dimmer can be included and operated in any Z-Wave network with other Z-Wave certified devices from other manufacturers and/or other applications. All non-battery operated nodes within the network will act as repeaters regardless of vendor to increase reliability of the network.

The encryption mode that the dimmer supports is S2 Unauthenticated. When the dimmer is being included into a Z-Wave network, you can use your primary controller/gateway to enable encryption mode or disable encryption. (The primary controller/gateway shall support encryption mode configuration). The dimmer supports OTA and can update firmware wirelessly.

Installation Guide

Please read carefully the enclosed user manual before installation of the in-wall dimmer, in order to ensure an error-free functioning.

Minimum Brightness Setting Button

1. Press and hold down the button for over 3 seconds: current brightness will be set as minimum brightness if it is lower than 50%. Minimum brightness will be reset to 1% if current brightness is higher than 50%.
2. Short press the button twice: the load's brightness will be set to 99%.

ATTENTION: Prior to the assembly of the product, the voltage network has to be switched OFF and ensured against re-switching.

Inclusion (adding to a Z-Wave network)

1. Set primary controller/gateway into inclusion mode (Please refer to your primary controllers manual on how to turn your controller into inclusion).
2. Power on the in-wall dimmer and set it into inclusion mode. There are two methods to set the in-wall dimmer into inclusion mode:
 - 1) Repower on the dimmer, it will be set into inclusion mode automatically, and waiting to be included.
 - 2) Triple press the action button on the dimmer, it will set the dimmer into inclusion mode. The connected light will stay solid on for 3 seconds to indicate successful inclusion.

Exclusion (removing from a Z-Wave network)

There are two exclusion methods:

Method 1: Exclusion from the primary controller/gateway as follows:

1. Set the primary controller/gateway into exclusion mode (Please refer to your primary controllers manual on how to set your controller into exclusion).
 2. Triple press the action button, the dimmer will be set to exclusion mode, and waiting to be excluded, then the dimmer will be excluded from the network.
- Method 2: Factory reset the dimmer will force the it to be excluded from a network. (please refer to the part "Factory Reset" of this manual)

Note: Factory reset is not recommended for exclusion, please use this procedure only if the primary controller/gateway is missing or otherwise inoperable.

Factory Reset

Press and hold down the action button for over 10 seconds, the dimmer will be reset to factory defaults.

Association

Z-Wave devices control other Z-Wave devices. The relationship between one device controlling another device is called association. In order to control a different device, the controlling device needs to maintain a list of devices that will receive controlling commands. These lists are called association groups and they are always related to certain events (e.g. button pressed). In case the event happens all devices stored in the respective association group will receive a common wireless command.

Association Groups:

Association Groups	Group Name	Max Nodes	Description
Group 1	Lifeline	5	1. When factory reset the dimmer, send "Device Reset Locally Notification CC" to associated devices of this group to report factory reset information. 2. When load state changes, send "Basic Report CC" to associated devices of this group. 3. When a load malfunction is detected, send "Emergency shutoff status" to Lifeline.

Set and unset associations:

(Note: All association information will be cleared automatically once the dimmer is excluded from a network.)

Set association by operating primary controller/gateway to send packets to the dimmer:

The primary controller/gateway sends packets to the dimmer using "Command Class ASSOCIATION"

Operating the device

Short press the action button on the dimmer to switch ON/OFF the load.

Node Information Frame

The Node Information Frame is the business card of a Z-Wave device. It contains information about the device type and the technical capabilities. The inclusion and exclusion of the device is confirmed by sending out a Node Information Frame. Beside this it may be needed for certain network operations to send out a Node Information Frame.

How to send out Node Information Frame:

When the dimmer is set to inclusion/exclusion mode again, it will send out Node Information Frame, there are 2 kinds of operation as follows:

- triple press the action button, the dimmer will be set to inclusion/exclusion mode, then send out Node Information Frame.
- When the dimmer is under inclusion mode, there are two kinds of operation:
 - Triple press inclusion/exclusion button, the dimmer will be set to inclusion mode again, and send out Node Information Frame.
 - Power off and power on the dimmer, it will be set to inclusion mode automatically, and send out Node Information Frame.

Technical Data

Wireless Range	up to 100 m outside, on average up to 40 m inside buildings
SDK	6.71.03
Explorer Frame Support	Yes
Device Type	Light Dimmer Switch
Generic Device Class	GENERIC_TYPE_SWITCH_MULTILEVEL
Specific Device Class	SPECIFIC_TYPE_POWER_SWITCH_MULTILEVEL
Role Type	Always On Slave (AOS)
Routing	Yes

SUPPORTED COMMAND CLASS

Node Info		Security Command Supported Report	
COMMAND_CLASS_ZWAVEPLUS_INFO	V2	COMMAND_CLASS_MANUFACTURER_SPECIFIC	V2
COMMAND_CLASS_TRANSPORT_SERVICE	V2	COMMAND_CLASS_VERSION	V2
COMMAND_CLASS_SECURITY	V1	COMMAND_CLASS_SWITCH_MULTILEVEL	V4

COMMAND_CLASS_SECURITY_2	V1	COMMAND_CLASS_SCENE_ACTIVATION	V1
COMMAND_CLASS_SUPERVISION	V1	COMMAND_CLASS_SCENE_ACTUATOR_CONF	V1
		COMMAND_CLASS_NOTIFICATION	V8
		COMMAND_CLASS_CONFIGURATION	V2
		COMMAND_CLASS_ASSOCIATION_GRP_INFO	V3
		COMMAND_CLASS_ASSOCIATION	V2
		COMMAND_CLASS_FIRMWARE_UPDATE_MD	V4
		COMMAND_CLASS_POWERLEVEL	V1
		COMMAND_CLASS_DEVICE_RESET_LOCALLY	V1

Notification Command Class

The dimmer supports Emergency shutoff, when inside temperature is over 90°C and detected by the built-in thermistance, the dimmer will send out Emergency shutoff status to Lifeline.

Notification Type	Notification
System (0x09)	Emergency shutoff status (0x07)

Configuration Command Class

Parameter	Size	Description	Default Value	
2	1	Info: Saving load state before power failure 0 – shutoff load 1 – turn on load 2 – save load state before power failure	2	
3	1	Info: Enable/disable to send the basic report to the Lifeline when the load state changed (When value set as 1, re-power on the dimmer, it will send Basic report automatically) 0 – Disable to send Basic report 1 – Enable to send Basic report	1	
4	1	Default fade time (unit is second, this value has the same function as Duration of Multilevel) Valid value: 0~0xFF	1	
		Value		Description
		0x00		Instantly
		0x01..0x7F		1 second (0x01) to 127 seconds (0x7F) in 1 second resolution.
		0x80..0xFE		1 minute (0x80) to 127 minutes (0xFE) in 1 minute resolution.
0xFF	Factory default duration. (1 second)			
5	1	Setting minimum brightness value Valid value: 0~50, the bigger the value is, the higher the load's minimum brightness is Note: when configure this value, the value of Multilevel will be configured as 1 automatically so that users can preview the corresponding effect of minimum brightness value	0	
6	1	Choose MOSFET driving type 0 – trailing edge 1 – leading edge	0	
7	1	Enable/disable external switch to be added to and removed from a network (when enables this function, triple press the external switch within 1.5 seconds to be added to or removed from a network) 0 - disable 1 - enable	1	

Wiring Diagram

(1) With dimmable LED light

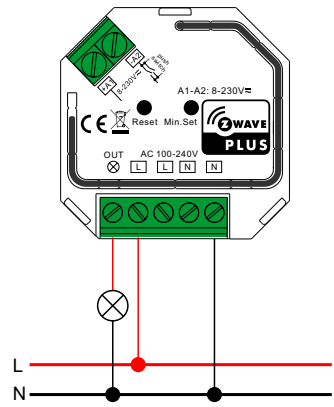

(2) With Push

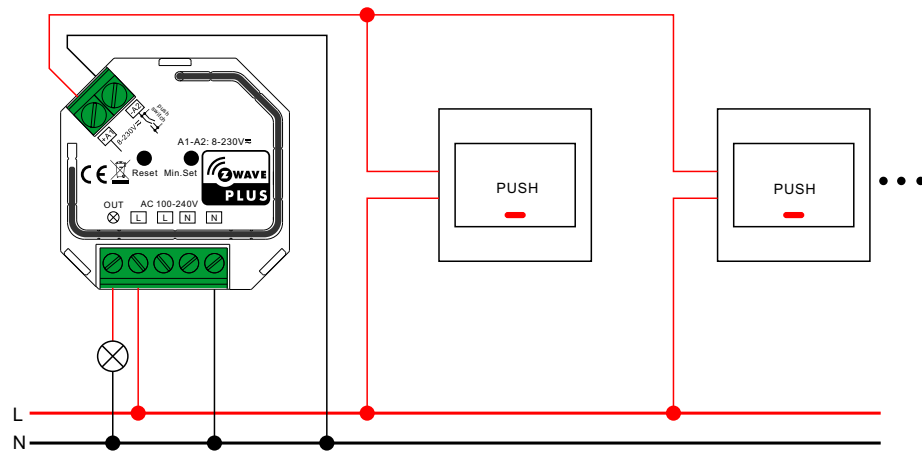

(3) With Push LV

