

# Z-Wave Push-button Coupler

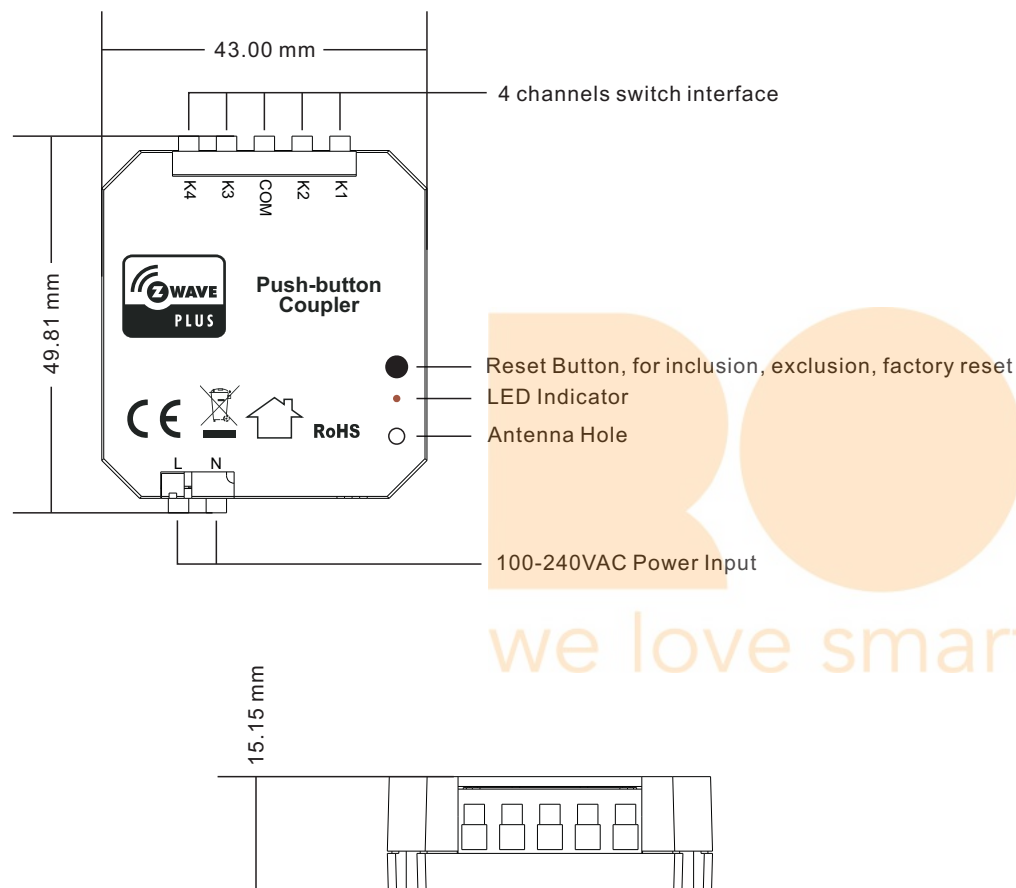

**Important:** Read All Instructions Prior to Installation

## Function introduction



## Product Data

Z-Wave Frequency	868.42MHz (EU)/908.42MHz (US)/921.42MHz (ANZ)
Power Supply	100-240VAC, 50/60Hz
Power Consumption	< 0.5W
Operating temperature	0 to 40°C
Relative humidity	8% to 80%
Dimensions	49.8x43x15.1mm
Waterproof Grade	IP20

## Safety & Warnings

- DO NOT install with power applied to the device.
- DO NOT expose the device to moisture.

## Quick Start

How to install:

- Step 1: power on the push-button coupler.
- Step 2: activate inclusion mode on your Z-Wave controller.
- Step 3: activate inclusion mode of the push button coupler by triple press the "reset" button. The coupler will be included to Z-Wave network.

## Product Description

The push-button coupler is a Z-Wave device that integrates existing switches into a Z-Wave system and converts the switches to wireless Z-Wave signal, the coupler can both control other Z-Wave devices and activate scenes in Gateways. The push-button coupler can be included and operated in any Z-Wave network with other Z-Wave certified devices from other manufacturers and/or other applications. All non-battery operated nodes within the network will act as repeaters regardless of vendor to increase reliability of the network.

Although it is controlling other devices, the device cannot act as Z-Wave network controller (primary or secondary) and will always need a Z-Wave network controller to be included into a Z-Wave network. It also supports the Over The Air (OTA) feature for the product's firmware upgrade.

This device supports the SmartStart inclusion. SmartStart enabled products can be added into a Z-Wave network by scanning the Z-Wave QR Code present on the product with a controller providing SmartStart inclusion. No further action is required and the SmartStart product will be added automatically within 10 minutes of being switched on in the network vicinity.

The push-button coupler has following functions:

1. Control of other Z-Wave devices using 'ON', 'OFF', Dim commands.
2. Activation of scenes in Gateway mode.

The encryption modes that the push-button coupler supports are S0, S2 Authenticated, S2 Unauthenticated. When the coupler is being included into a Z-Wave network, you can use your primary controller/gateway to enable one encryption mode or disable encryption. (The primary controller/gateway shall support encryption mode configuration).

## Installation Guide

Please read carefully the enclosed user manual before installation of push-button coupler, in order to ensure an error-free functioning.

The push-button coupler unit supplied as complete set for flush mounting in the standard European size wall boxes.

**ATTENTION:** Only authorized technicians under consideration of the country specific installation guidelines/norms may do works with 100-240V mains power. Prior to the assembly of the product, the voltage network has to be switched OFF and ensured against re-switching.

## Inclusion (Adding to a Z-Wave network)

Step 1. Make sure the push-button coupler does not belong to any Z-Wave network, short press any button, if LED indicator flashes 3 times slowly, the coupler does not belong to any network, then continue step 2, otherwise, it means the coupler has already been included to a network, please first set the coupler to exclusion mode (refer to the part "Exclusion" of this manual), then continue step 2.

Step 2. Set primary controller/gateway into inclusion mode (Please refer to your primary controllers manual on how to turn your controller into inclusion).

Step 3. Set the coupler to inclusion mode, there are two methods as follows:

- 1) Triple press the "reset" button, the coupler will be set to inclusion mode, and waiting to be included.
- 2) Power off and power on the coupler, it will be set to inclusion mode, and waiting to be included.

The coupler is a sleepy device, after inclusion it will not enter into sleepy mode immediately, and will continue activation status for 10s and wait data interaction from the gateway, the LED indicator will flash quickly, please

be patient to wait LED indicator to turn off.

**Exclusion (Removing from a Z-Wave network)**

There are two exclusion methods:

Method 1: Exclusion from the primary controller/gateway as follows:

1. Set the primary controller/gateway into exclusion mode (Please refer to your primary controllers manual on how to set your controller into exclusion).
2. Triple press the "reset" button, the coupler will be set to exclusion mode, and waiting to be excluded.

Method 2: Factory reset the coupler will force it to be excluded from a network. (please refer to the part "Factory Reset" of this manual)

Note: Factory reset is not recommended for exclusion, please use this procedure only if the primary controller/gateway is missing or otherwise inoperable.

**How to check whether the coupler already included to a network**

Short press any button, if LED indicator flashes 3 times slowly, the coupler does not belong to any network, otherwise, it means the coupler has already been included to a network.

If the coupler already belongs to a network, follow the exclusion process before including it in your network. Otherwise inclusion of this device will fail.

**Factory Reset**

Press and hold down the "reset" button for 10 seconds, LED indicator turns on and then blinks slowly to indicate successful factory reset.

**Association**

Z-Wave devices control other Z-Wave devices. The relationship between one device controlling another device is called association. In order to control a different device, the controlling device needs to maintain a list of devices that will receive controlling commands. These lists are called association groups and they are always related to certain events (e.g. button pressed). In case the event happens all devices stored in the respective association group will receive a common wireless command.

**Association Groups:**

Each group supports maximum 5 nodes for association, the same device can be associated with multiple groups on the remote control simultaneously, to ensure better control experience, the remote control shall remove the associated devices that are not under working status from association groups in time.

Function of the connected switches varies when it is configured via configuration parameter 9, the association groups information based on different functions of the switches are as follows:

**Function 1 (value of configuration parameter 9 configured as 0)**

Association Groups	Group Name	Max Nodes	Description
Group 1	Lifeline	5	<ol style="list-style-type: none"> <li>1. Send Command Class "Device Reset Locally Notification" to associated devices of this group to report factory reset information when factory reset the remote control by pressing and holding down the "reset" button for 10 seconds.</li> <li>2. Short press once or twice, press and hold down, release the any of connected switch buttons K1, K2, K3, K4 to send scene activation command to the associated devices of this group using Command Class "Central Scene". The actions of each switch button that trigger central scene can be configured via parameters 5-8.</li> <li>3. When push-button coupler battery power value changes, send Command Class "Battery Report" to associated devices of this group to report power value information.</li> </ol>

Group 2	Launch 1	5	<ol style="list-style-type: none"> <li>1. Short press the switch button K1 (or K1+K2 or K1+K2+K3+K4) to send ON/OFF command to associated devices of this group using Command Class "Basic Set 0xff/0x00".</li> <li>2. Press and hold the switch button K1 (or K1+K2 or K1+K2+K3+K4) to send Dim command to associated devices of this group using Command Class "Multilevel Start Level Change Up/Down". (This Command only works when connected switch type is configured as push button, value of configuration parameter 2 configured as 0)</li> </ol>
Group 3	Launch 2	5	<ol style="list-style-type: none"> <li>1. Short press the switch button K2 (or K3+K4) to send ON/OFF command to associated devices of this group using Command Class "Basic Set 0xff/0x00".</li> <li>2. Press and hold the switch button K2 (or K3+K4) to send Dim command to associated devices of this group using Command Class "Multilevel Start Level Change Up/Down". (This Command only works when connected switch type is configured as push button, value of configuration parameter 2 configured as 0)</li> </ol>
Group 4	Launch 3	5	<ol style="list-style-type: none"> <li>1. Short press the switch button K3 to send ON/OFF command to associated devices of this group using Command Class "Basic Set 0xff/0x00".</li> <li>2. Press and hold the switch button K3 to send Dim command to associated devices of this group using Command Class "Multilevel Start Level Change Up/Down". (This Command only works when connected switch type is configured as push button, value of configuration parameter 2 configured as 0)</li> </ol>
Group 5	Launch 4	5	<ol style="list-style-type: none"> <li>1. Short press the switch button K4 to send ON/OFF command to associated devices of this group using Command Class "Basic Set 0xff/0x00".</li> <li>2. Press and hold the switch button K4 to send Dim command to associated devices of this group using Command Class "Multilevel Start Level Change Up/Down". (This Command only works when connected switch type is configured as push button, value of configuration parameter 2 configured as 0)</li> </ol>

**Function 2 (value of configuration parameter 9 configured as 1)**

Association Groups	Group Name	Max Nodes	Description
Group 1	Lifeline	5	<ol style="list-style-type: none"> <li>1. Send Command Class "Device Reset Locally Notification" to associated devices of this group to report factory reset information when factory reset the remote control by pressing and holding down the "reset" button for 10 seconds.</li> <li>2. Short press once or twice, press and hold down, release the any of connected switch buttons K1, K2, K3, K4 to send scene activation command to the associated devices of this group using Command Class "Central Scene". The actions of each switch button that trigger central scene can be configured via parameters 5-8.</li> <li>3. When push-button coupler battery power value changes, send Command Class "Battery Report" to associated devices of this group to report power value information.</li> </ol>

Group 2	Launch 1	5	<ol style="list-style-type: none"> <li>1. Short press the switch button K1 (or K1+K2) to send ON command to associated devices of this group using Command Class "Basic Set 0xff".</li> <li>2. Short press the switch button K2 (or K3+K4) to send OFF command to associated devices of this group using Command Class "Basic Set 0x00".</li> <li>3. Press and hold the switch button K1 (or K1+K2) to send Dim up command to associated devices of this group using Command Class "Multilevel Start Level Change Up". (This Command only works when connected switch type is configured as push button, value of configuration parameter 2 configured as 0)</li> <li>4. Press and hold the switch button K2 (or K3+K4) to send Dim down command to associated devices of this group using Command Class "Multilevel Start Level Change Down". (This Command only works when connected switch type is configured as push button, value of configuration parameter 2 configured as 0)</li> </ol>
Group 3	Launch 2	5	<ol style="list-style-type: none"> <li>1. Short press the switch button K3 to send ON command to associated devices of this group using Command Class "Basic Set 0xff".</li> <li>2. Short press the switch button K4 to send OFF command to associated devices of this group using Command Class "Basic Set 0x00".</li> <li>3. Press and hold the switch button K3 to send Dim up command to associated devices of this group using Command Class "Multilevel Start Level Change Up". (This Command only works when connected switch type is configured as push button, value of configuration parameter 2 configured as 0)</li> <li>4. Press and hold the switch button K4 to send Dim down command to associated devices of this group using Command Class "Multilevel Start Level Change Down". (This Command only works when connected switch type is configured as push button, value of configuration parameter 2 configured as 0)</li> </ol>

**Function 3 (value of configuration parameter 9 configured as 2)**

Association Groups	Group Name	Max Nodes	Description
Group 1	Lifeline	5	<ol style="list-style-type: none"> <li>1. Send Command Class "Device Reset Locally Notification" to associated devices of this group to report factory reset information when factory reset the remote control by pressing and holding down the "reset" button for 10 seconds.</li> <li>2. Short press once or twice, press and hold down, release the any of connected switch buttons K1, K2, K3, K4 to send scene activation command to the associated devices of this group using Command Class "Central Scene". The actions of each switch button that trigger central scene can be configured via parameters 5-8.</li> <li>3. When push-button coupler battery power value changes, send Command Class "Battery Report" to associated devices of this group to report power value information.</li> </ol>

Group 2	Launch 1	5	<ol style="list-style-type: none"> <li>1. Short press the switch button K1 to send ON command to associated devices of this group using Command Class "Basic Set 0xff".</li> <li>2. Short press the switch button K2 to send OFF command to associated devices of this group using Command Class "Basic Set 0x00".</li> <li>3. Press and hold the switch button K1 to send Dim up command to associated devices of this group using Command Class "Multilevel Start Level Change Up". (This Command only works when connected switch type is configured as push button, value of configuration parameter 2 configured as 0)</li> <li>4. Press and hold the switch button K2 to send Dim down command to associated devices of this group using Command Class "Multilevel Start Level Change Down". (This Command only works when connected switch type is configured as push button, value of configuration parameter 2 configured as 0)</li> <li>5. Press and hold the switch button K3 (or K1+K2) to send scene saving command to associated devices of this group using Command Class "Scene Actuator Configuration CC", scene ID=0x10. (This Command only works when connected switch type is configured as push button, value of configuration parameter 2 configured as 0)</li> <li>6. Press and hold the switch button K4 (or K3+K4) to send scene saving command to associated devices of this group using Command Class "Scene Actuator Configuration CC", scene ID=0x20. (This Command only works when connected switch type is configured as push button, value of configuration parameter 2 configured as 0)</li> <li>7. Short press the switch button K3 (or K1+K2) to send scene recall command to associated devices of this group using Command Class "Scene Activation CC", scene ID=0x10. (This Command only works when connected switch type is configured as push button, value of configuration parameter 2 configured as 0)</li> <li>8. Short press the switch button K4 (or K3+K4) to send scene recall command to associated devices of this group using Command Class "Scene Activation CC", scene ID=0x20. (This Command only works when connected switch type is configured as push button, value of configuration parameter 2 configured as 0)</li> </ol>
---------	----------	---	---

**Set and unset associations:**

(Note: All association information will be cleared automatically once the push button coupler is excluded from a network.)

Set association by operating primary controller/gateway to send association command to the coupler:

When set association from primary controller/gateway, the push button coupler shall be activated first, if it is not activated, you should activate it manually.

The primary controller/gateway sends association command to the push button coupler using "Command Class ASSOCIATION" or "Command Class Multi Channel Association"

**Operate the device:**

**Function 1 (value of configuration parameter 9 configured as 0)**

- Short press once, twice, press and hold down, release any of the connected switch buttons K1, K2, K3, K4 to send scene activation command to association group 1 using Command Class "Central Scene".

- Short press the connected switch button K1/K2/K3/K4 to send ON/OFF command to all associated devices of Association Group 2/3/4/5 using Command Class "Basic Set 0xff/0x00".

- Press and hold the connected switch button K1/K2/K3/K4 to send light intensity increase/decrease command to all associated devices of Association Group 2/3/4/5 using Command Class "Multilevel Start Level Change Up/Down". (Only works when connected switch type is configured as push button, value of configuration parameter 2 configured as 0)

#### Function 2 (value of configuration parameter 9 configured as 1)

- Short press once, twice, press and hold down, release any of the connected switch buttons K1, K2, K3, K4 to send scene activation command to association group 1 using Command Class "Central Scene".

- Short press the switch button K1 to send ON command to all associated devices of Association Group 2 using Command Class "Basic Set 0xff", short press the switch button K2 to send OFF command to all associated devices of Association Group 2 using Command Class "Basic Set 0x00".

- Press and hold the switch button K1 to send light intensity increase command to all associated devices of Association Group 2 using Command Class "Multilevel Start Level Change Up", press and hold the switch button K2 to send light intensity decrease command to all associated devices of Association Group 2 using Command Class "Multilevel Start Level Change Down". (Only works when connected switch type is configured as push button, value of configuration parameter 2 configured as 0)

- Short press the switch button K3 to send ON command to all associated devices of Association Group 3 using Command Class "Basic Set 0xff", short press the switch button K4 to send OFF command to all associated devices of Association Group 3 using Command Class "Basic Set 0x00".

- Press and hold the switch button K3 to send light intensity increase command to all associated devices of Association Group 3 using Command Class "Multilevel Start Level Change Up", press and hold the switch button K4 to send light intensity decrease command to all associated devices of Association Group 3 using Command Class "Multilevel Start Level Change Down". (Only works when connected switch type is configured as push button, value of configuration parameter 2 configured as 0)

#### Function 3 (value of configuration parameter 9 configured as 2)

- Short press once, twice, press and hold down, release any of the connected switch buttons K1, K2, K3, K4 to send scene activation command to association group 1 using Command Class "Central Scene".

- Short press the switch button K1 to send ON command to all associated devices of Association Group 2 using Command Class "Basic Set 0xff", short press the switch button K2 to send OFF command to all associated devices of Association Group 2 using Command Class "Basic Set 0x00".

- Press and hold the switch button K1 to send light intensity increase command to all associated devices of Association Group 2 using Command Class "Multilevel Start Level Change Up", press and hold the switch button K2 to send light intensity decrease command to all associated devices of Association Group 2 using Command Class "Multilevel Start Level Change Down". (Only works when connected switch type is configured as push button, value of configuration parameter 2 configured as 0)

- Press and hold switch button K3/K4 button to send scene saving command to all associated devices of Association Group 2 using Command Class "Scene Actuator Configuration", Scene ID = 0x10 / 0x20. (Only works when connected switch type is configured as push button, value of configuration parameter 2 configured as 0)

- Short press switch button K3/K4 button to send scene recall command to all associated devices of Association Group 2 using Command Class "Scene Activation", Scene ID = 0x10 / 0x20. (Only works when connected switch type is configured as push button, value of configuration parameter 2 configured as 0)

#### How to communicate with the device

The push button coupler is under sleepy mode for most of the time to save battery power. It can not receive wireless command under sleepy mode. Before the gateway interacts data with the push button coupler, the push button coupler shall be activated manually first. Press and hold down the "reset" button for 1 second to activate the push button coupler.

#### Node Information Frame

The Node Information Frame is the business card of a Z-Wave device. It contains information about the device type and the technical capabilities. The inclusion and exclusion of the device is confirmed by sending out a Node Information Frame. Beside this it may be needed for certain network operations to send out a Node Information Frame.

#### How to send out Node Information Frame:

Set the push button coupler into inclusion/exclusion mode: triple press the "reset" button, LED indicator turns on to indicate the push button coupler has already sent out Node Information Frame, the user can repeat the operation to set the push button coupler to quit "inclusion/exclusion mode".

#### Technical Data

Power Supply	100-240VAC, 50/60Hz
Frequency	868.42 MHz (EU)/908.42MHz (US)/921.42MHz (ANZ)
Wireless Range	up to 100 m outside, on average up to 40 m inside buildings
SDK	7.11.1
Explorer Frame Support	Yes
Device Type	Central Scene
Generic Device Class	WALL CONTROLLER
Specific Device Class	Not Used
Supporting Device Type	Actuator
Requested security keys	S0, S2_UNAUTHENTICATED and S2_AUTHENTICATED
Routing	No
FLIRS	No

#### Z-Wave Plus Info

Parameter	Value
Z-Wave Plus Version	2
Role Type	Reporting Sleeping Slave (RSS)
Node Type	ZWAVEPLUS
Installer Icon Type	0x1600(ICON_TYPE_GENERIC_WALL_CONTROLLER)
User Icon Type	0x1600(ICON_TYPE_GENERIC_WALL_CONTROLLER)

#### Manufacturer Specific

Parameter	Value (hex)
Manufacturer ID	0x330
Product Type ID	EU=0x0400, US=0X0401, ANZ=0X0402, RU=0x0407
Product ID	0x04

#### SUPPORTED COMMAND CLASS

Command Class	Version	Required Security Class
Association	2	Highest granted Security Class
Association Group Info	3	Highest granted Security Class
Central Scene	3	Highest granted Security Class
Configuration	4	Highest granted Security Class

Device Reset Locally	1	Highest granted Security Class
Firmware Update Meta Data	5	Highest granted Security Class
Indicator	3	Highest granted Security Class
Manufacture Specific	2	Highest granted Security Class
Multi Channel Association	3	Highest granted Security Class
Notification	8	Highest granted Security Class
Powerlevel	1	Highest granted Security Class
Version	3	Highest granted Security Class
Security 0	1	None
Security 2	1	None
Supervision	1	None
Transport Service	2	None
Z-Wave Plus Info	2	None

#### Basic Command Class mapping

Basic Command Class is not mapped to any of the supported command classes.

#### Configuration Command Class

Parameter	Size	Description	Default Value
2	1	<b>External switch type</b> 0 - Push button 1 - Normal On/Off switch 2 - 3-Way switch	0
3	1	<b>Duration of the Multilevel Start Level Change Up/Down</b> Set the duration of the Multilevel Start Level Change Up/Down sent when pressing and holding the push button, Valid value: 0-100	8
4	1	<b>Associations in Z-Wave network Security Mode</b> Enable or disable to set association with association groups in Z-Wave network Security Mode (this parameter is only valid when the coupler is added to an encrypted network): 0 - disable the setting for all association groups 2, 3, 4&5 1 - enable the setting for association group 2 2 - enable the setting for association group 3 4 - enable the setting for association group 4 8 - enable the setting for association group 5  The valid value of this parameter can be a combination, for instance, when set the parameter as 1+2=3, the settings for both association groups 2 and 3 are enabled.	15

5	1	<b>Scenes sent to the controller for button 1</b> This parameter defines the actions of push button 1 which can trigger Central Scene (sent to Lifeline group): 1 - button short pressed once 2 - button short pressed twice 4 - button pressed and held 8 - button released  The valid value of this parameter can be a combination, for instance, when set the parameter as 1+2=3, the actions of short pressed once and short pressed twice will both work.	15
6	1	<b>Scenes sent to the controller for button 2</b> This parameter defines the actions of push button 2 which can trigger Central Scene (sent to Lifeline group): 1 - button short pressed once 2 - button short pressed twice 4 - button pressed and held 8 - button released  The valid value of this parameter can be a combination, for instance, when set the parameter as 1+2=3, the actions of short pressed once and short pressed twice will both work.	15
7	1	<b>Scenes sent to the controller for button 3</b> This parameter defines the actions of push button 3 which can trigger Central Scene (sent to Lifeline group): 1 - button short pressed once 2 - button short pressed twice 4 - button pressed and held 8 - button released  The valid value of this parameter can be a combination, for instance, when set the parameter as 1+2=3, the actions of short pressed once and short pressed twice will both work.	15
8	1	<b>Scenes sent to the controller for button 4</b> This parameter defines the actions of push button 4 which can trigger Central Scene (sent to Lifeline group): 1 - button short pressed once 2 - button short pressed twice 4 - button pressed and held 8 - button released  The valid value of this parameter can be a combination, for instance, when set the parameter as 1+2=3, the actions of short pressed once and short pressed twice will both work.	15
9	1	<b>Function of the connected switches</b> This parameter defines the function of the connected switches: 0 - function 1 1 - function 2 2 - function 3	0

#### Wiring Diagram

##### Notes for the diagrams:

**L** - terminal for live lead input

**N** - terminal for neutral lead input

**K1, K2, K3, K4** - terminals for connecting to output terminal of the switches

**COM** - common terminal for connecting to input terminal of the switches

(1) Push Button Switch Connection

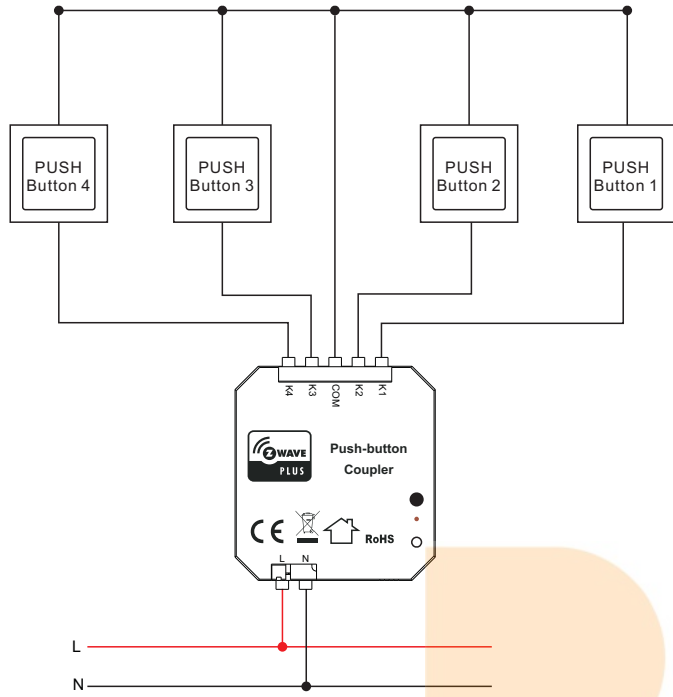

(3) 3-Way Switch Connection

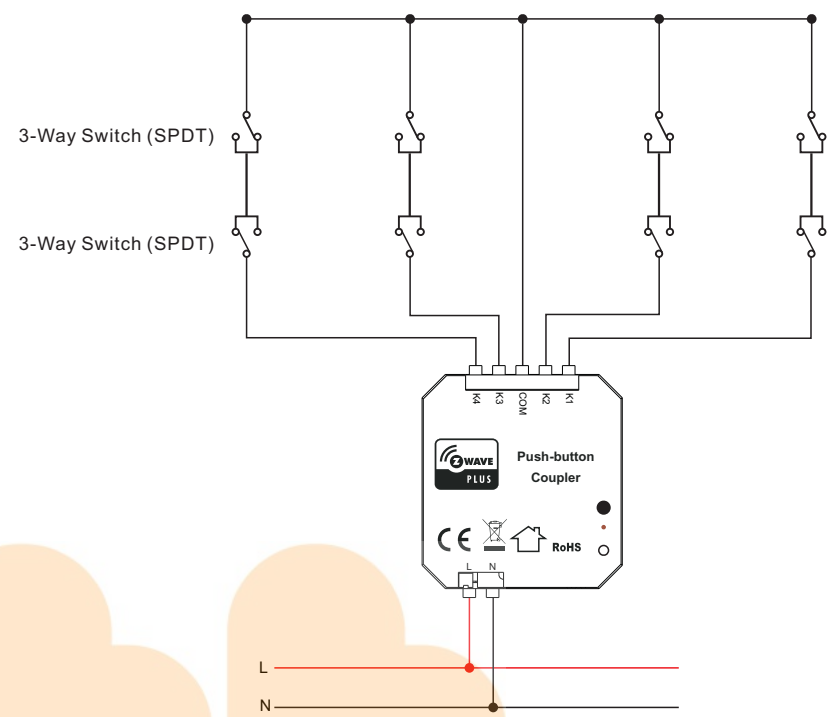

(2) Normal On/Off Switch Connection

