



**Steinel Z-Wave Interface
v 1.0.0**

Steinel Z-Wave Interface Specification

1	ABBREVIATIONS	3	3	DEVICE USE	8
2	Z-WAVE ARCHITECTURE	3	3.1	Basic Z-Wave functions	8
2.1	Specification	3	3.2	Intended use of system	8
2.2	Diagram of multichannel device	3	3.2.1	Ambient light	8
2.3	Z-Wave plus icons	3	3.2.2	Motion events	10
2.3.1	Icons for multilevel lamp ^(SMUL)	3	3.2.2.1	Setting up motion detection groups	11
2.3.2	Icons for binary lamp ^(SBIN)	3	3.2.3	Direct control function	11
2.3.3	Icons for pir sensor ^(SPIR)	3	3.2.4	Control via common Z-Wave commands	12
2.4	AGI (Association Group Information) tables	3	3.2.5	Motion sensor inactivity and local disable possibilities	12
2.4.1	Root device	4	3.2.6	Manual override functions	14
2.4.2	Lamp ^(SLAMP) / Relay ^(SPIR) endpoint	4	3.3	Special functions	14
2.4.3	Motion sensor endpoint	4	3.3.1	Security System function	14
2.4.4	Light sensor endpoint	4	3.3.2	"Light Teach" function	14
2.4.5	Button endpoint ^(STOGGLE)	4	3.3.3	"Slow light ramp up and down" function	14
2.5	NIF (Node Information Frame)	5			
2.5.1	Root ^(SPIR)	5			
2.5.2	Root ^(SLAMP)	5			
2.5.3	Lamp ^(SLAMP) / Relay ^(SPIR)	5			
2.5.4	Motion sensor	6			
2.5.5	Light sensor	6			
2.5.6	Button ^(STOGGLE)	6			
2.6	Configuration	6			

1 ABBREVIATIONS

Abbreviation	Explanation
ZW	Z-Wave
SZW	Steinel Z-Wave module (software for Z-Wave interface)
CC	Command class

Limited text validity	Explanation
SPiR	Text valid only for standalone PIR sensor with relay (e.g.: IS140-2)
SLAMP	Text valid only for sensor Steinel lamp (e.g.: L810 iHF, D2 or XLED HOME 1)
SBiN	Text valid only for binary sensor Steinel lamp (e.g.: D2 or XLED HOME 1)
SMUL	Text valid only for multilevel sensor Steinel lamp (e.g.: L810 iHF)
STOGGLE	Text valid only for Steinel lamp or PIR with toggle button (used as switch endpoint)
SKNOB	Text valid only for Steinel device with Link knob instead of Link button

2 Z-WAVE ARCHITECTURE

2.1 Specification

Z-Wave Plus

Role type: Slave Always On = AOS
 Protocol Library: Enhanced Slave 232
 Manufacturer: 0x0271
 Product Type:
 L810 iHF: 6773 Light Dimmer Switch
 XLED HOME 1: 6771 ON/OFF Power Switch
 D2: 6772 ON/OFF Power Switch
 IS140-2: 6770 Sensor - Notification

Product ID: 0001
 0002

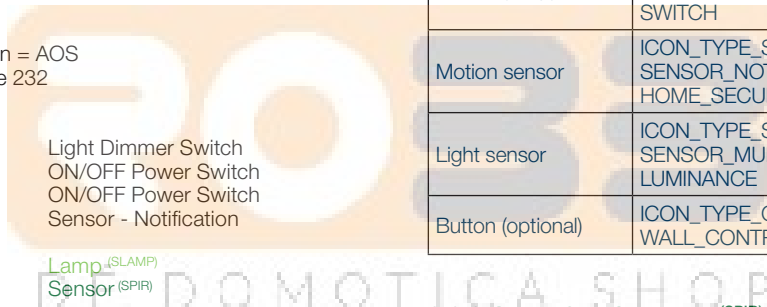

2.2 Diagram of multichannel device

Root Configuration, FW update, naming and other mandatory classes. Mirror of primary functions, full mirror of endpoint 1, partial mirror of other endpoints		
endpoint 1 (SLAMP) / 3 (SPiR) "SWITCH" Lamp (SLAMP) / Relay (SPiR) Device Type: On/Off Power Switch (SPiR) On/Off Power Switch (SBiN) ON/OFF Dimmer (SMUL) Output commands: Controls associated devices via BASIC SET command (controlled by motion sensor) – Master/Slave mode Incoming commands: Motion notification - taken as internal motion detection. Motion detection events are stored in a table for each device. Basic Set, Binary Switch Set (SPiR) Binary Switch Set (SBiN) Multilevel Switch Set (SMUL) Scenes (SLAMP) Switch All	endpoint 2 (SLAMP) / 1 (SPiR) "MOTION" (PIR or Motion/iHF radar) Device Type: Sensor-Notification Output commands: Sends Motion Begin/End events to attached devices. No incoming commands.	endpoint 3 (SLAMP) / 2 (SPiR) "LIGHT SENSOR" Device Type: Sensor-Multilevel Output commands: Presents current measured value. Incoming commands: Multilevel sensor report (light) – replaces internal value (optionally). endpoint 4 (STOGGLE) "BUTTON" Device Type: Wall controller Output commands: Basic Set, Central scene notification Incoming commands: Central scene

2.3 Z-Wave plus icons

2.3.1 Icons for multilevel lamp (SMUL)

Endpoint	Installer Icon	User Icon
Root	ICON_TYPE_GENERIC_LIGHT_DIMMER_SWITCH	ICON_TYPE_GENERIC_LIGHT_DIMMER_SWITCH
Switch (lamp)	ICON_TYPE_GENERIC_LIGHT_DIMMER_SWITCH	ICON_TYPE_GENERIC_LIGHT_DIMMER_SWITCH
Motion sensor	ICON_TYPE_SPECIFIC_SENSOR_NOTIFICATION_HOME_SECURITY	ICON_TYPE_SPECIFIC_SENSOR_NOTIFICATION_HOME_SECURITY
Light sensor	ICON_TYPE_SPECIFIC_SENSOR_MULTILEVEL_LUMINANCE	ICON_TYPE_SPECIFIC_SENSOR_MULTILEVEL_LUMINANCE
Button (optional)	ICON_TYPE_GENERIC_WALL_CONTROLLER	ICON_TYPE_GENERIC_WALL_CONTROLLER

2.3.2 Icons for binary lamp (SBiN)

Endpoint	Installer Icon	User Icon
Root	ICON_TYPE_GENERIC_ON_OFF_POWER_SWITCH	ICON_TYPE_GENERIC_ON_OFF_POWER_SWITCH
Switch (lamp)	ICON_TYPE_GENERIC_ON_OFF_POWER_SWITCH	ICON_TYPE_GENERIC_ON_OFF_POWER_SWITCH
Motion sensor	ICON_TYPE_SPECIFIC_SENSOR_NOTIFICATION_HOME_SECURITY	ICON_TYPE_SPECIFIC_SENSOR_NOTIFICATION_HOME_SECURITY
Light sensor	ICON_TYPE_SPECIFIC_SENSOR_MULTILEVEL_LUMINANCE	ICON_TYPE_SPECIFIC_SENSOR_MULTILEVEL_LUMINANCE
Button (optional)	ICON_TYPE_GENERIC_WALL_CONTROLLER	ICON_TYPE_GENERIC_WALL_CONTROLLER

2.3.3 Icons for pir sensor (SPiR)

Endpoint	Installer Icon	User Icon
Root	ICON_TYPE_SPECIFIC_SENSOR_NOTIFICATION_HOME_SECURITY	ICON_TYPE_SPECIFIC_SENSOR_NOTIFICATION_HOME_SECURITY
Motion sensor	ICON_TYPE_SPECIFIC_SENSOR_NOTIFICATION_HOME_SECURITY	ICON_TYPE_SPECIFIC_SENSOR_NOTIFICATION_HOME_SECURITY
Light sensor	ICON_TYPE_SPECIFIC_SENSOR_MULTILEVEL_LUMINANCE	ICON_TYPE_SPECIFIC_SENSOR_MULTILEVEL_LUMINANCE
Switch (relay)	ICON_TYPE_GENERIC_ON_OFF_POWER_SWITCH	ICON_TYPE_GENERIC_ON_OFF_POWER_SWITCH
Button (optional)	ICON_TYPE_GENERIC_WALL_CONTROLLER	ICON_TYPE_GENERIC_WALL_CONTROLLER

2.4 AGI (Association Group Information) tables

The primary or inclusion controller should ensure the correct association of devices into the network during installation.

2.4.1 Root device

Group	Max Nodes	Profile	Command Class and Command (list)	Group Name (UTF-8)
1	1	General: Lifeline	Device Reset Locally Notification Notification Report Binary Switch Report ^(SPIR) Binary Switch Report ^(SBIN) Multilevel Switch Report ^(SMUL) Multilevel Sensor Report Central Scene Notification ^(STOGGLE)	Lifeline
2	16	Control: Key01	Basic Set	On/Off control
3	16	Notification: Motion	Notification Report	Motion Begin/End (PIR/radar/IHF)
4	15	Sensor: Luminescence	Multilevel Sensor Report	Ambient light
5 ^{STOGGLE}	16	Control: Key02	Basic Set	On/Off button

Lifeline messages

- Device Reset Locally (immediately)
- Notifications:
 - 0x09 (System) – Hardware failure with manufacturer proprietary code (0x03)
 - 0x09 (System) – Software failure with manufacturer proprietary code (0x04)
 - 0x07 (Home security) – Motion Begin event (0x08)
 - 0x07 (Home security) – Motion End event (0x00, 0x08)
- Binary Switch Report ^(SPIR)
- Binary Switch Report ^(SBIN)
- Multilevel Switch Report ^(SMUL)
- Multilevel Sensor Report – value of internal ambient light sensor
- Central scene notification ^(STOGGLE)

Motion Begin and Motion End events are sent along with frames to group 3. If multichannel association is created the events are sent from motion sensor endpoint.

Switch Report is sent immediately upon a change of status along with frames to group 2. If multichannel association is created the events are sent from lamp/relay endpoint.

Multilevel Sensor Report is sent a maximum of once per 1 minute (if the value has changed by at least 3%) and a minimum of once per 15 minutes (if the value has not changed). If the ambient light value is old (cannot be measured because of permanent light), the value is not transmitted via lifeline. Multilevel Sensor Report can also be added to some other events to send in bulk. If multichannel association is created the events are sent from light sensor endpoint.

Central scene notification is sent as reaction to user interaction. If multichannel association is created the events are sent from toggle button endpoint.

All notifications to lifeline are sent as sensor states regardless of sensor settings and states as SLAVE_MODE, LOCAL_DISABLED and MOTION_ENABLE.

Group 2 is used for directly controlling Z-Wave devices via BASIC SET commands through the evaluation of movement and light, as with internal use (so that all of these devices work together). This is intended for use especially with third-party devices that do not implement reactions for motion events. BASIC_SET and similar Z-Wave commands are not retransmitted intentionally to slaves and must be sent to slave devices via the controlling device simultaneously. Only for use in master-slave system, multi-device control is not possible.

Group 2 is evaluated and frames are transmitted there also in SLAVE_MODE, regardless of LOCAL_DISABLED state and when MOTION_ENABLE is off (not using internal motion sensor, just reacting to remote motion events in this case).

If multichannel association is created the events are sent from motion sensor endpoint.

Group 3 sends MOTION_BEGIN and MOTION_END frames.
MOTION_BEGIN frame = Notification 0x07 (Home security) – Motion detection without location (0x08)
MOTION_END frame = Notification 0x07 (Home security) – Event inactive (0x00, parameter 0x08)

After the first motion detection, MOTION_BEGIN is sent. If continual movement is detected, MOTION_BEGIN is sent every 1 minute repeatedly. When motion ends, MOTION_END is sent 5 seconds after the last motion detection.

Notification to group 3 is sent only when NIGHT_MODE = ON and MOTION_ENABLE = ON, regardless of LOCAL_DISABLED state.

All devices in a group should have the same TIME settings in order that they switch off at the same time.

If multichannel association is created the events are sent from motion sensor endpoint.

Ambient Light via **Group 4** is intended to substitute locally measured LUX values in target devices – so that the network can have one source of ambient light value. Frames are sent a maximum of once per 2.5 minutes and a minimum of once per 15 minutes.

When device already uses remote Ambient Light value, then this value is also retransmitted to group 4.

All devices in such a group should have the same LIGHT (threshold) settings in order that night mode is detected at the same time.

If multichannel association is created the events are sent from light sensor endpoint.

Group 5 is used for directly controlling Z-Wave devices via BASIC SET commands by button. ^(STOGGLE)

If multichannel association is created the events are sent from toggle button endpoint.

2.4.2 Lamp ^(SLAMP) / Relay ^(SPIR) endpoint

Endpoint 1 ^(SLAMP) / Endpoint 3 ^(SPIR)

Group	Max Nodes	Profile	Command Class and Command (list)	Group Name (UTF-8)
1	1 (mirror of root 1)	Control: Key01	Binary Switch Report ^(SPIR) Binary Switch Report ^(SBIN) Multilevel Switch Report ^(SMUL)	<Binary/Multilevel> Switch Report (via Lifeline)

2.4.3 Motion sensor endpoint

Endpoint 2 ^(SLAMP) / Endpoint 1 ^(SPIR)

Group	Max Nodes	Profile	Command Class and Command (list)	Group Name (UTF-8)
1	1 (mirror of root 1)	Notification: Motion	Notification Report	<PIR/Motion/IHF> (via Lifeline)
2	16 (mirror of root 2)	Control: Key01	Basic Set	On/Off control
3	16 (mirror of root 3)	Notification: Motion	Notification Report	Motion Begin/End <PIR/radar/IHF>

2.4.4 Light sensor endpoint

Endpoint 3 ^(SLAMP) / Endpoint 2 ^(SPIR)

Group	Max Nodes	Profile	Command Class and Command (list)	Group Name (UTF-8)
1	1 (mirror of root 1)	Sensor: Luminescence	Multilevel Sensor Report	Ambient Light (via Lifeline)
2	16 (mirror of root 4)	Sensor: Luminescence	Multilevel Sensor Report	Ambient Light

2.4.5 Button endpoint ^(STOGGLE)

Endpoint 4

Group	Max Nodes	Profile	Command Class and Command (list)	Group Name (UTF-8)
1	1 (mirror of root 1)	Control: Key02	Central Scene Notification	Button notification (via Lifeline)
2	16 (mirror of root 5)	Control: Key02	Basic Set	On/Off button

2.5 NIF (Node Information Frame)

NIF specifies the type and abilities (supported command classes) of the device (and each of the endpoints).

2.5.1 Root (SPIR)

NIF (Node Information frame)	
Listening = YES	Protocol Specific Part
Opt. Func = YES	Protocol Specific Part
Protocol Specific Part	
Basic Device Class = BASIC_TYPE_ROUTING_SLAVE (Protocol Specific Part)	
Binary Sensor Device Class = GENERIC_TYPE_SENSOR_NOTIFICATION	
Routing Binary Sensor Specific Device Class = SPECIFIC_TYPE_NOTIFICATION_SENSOR	
COMMAND_CLASS_ZWAVEPLUS_INFO (v2)	
COMMAND_CLASS_VERSION (v2)	
COMMAND_CLASS_FIRMWARE_UPDATE_MD (v3)	
COMMAND_CLASS_MANUFACTURER_SPECIFIC (v2)	
COMMAND_CLASS_MULTI_CHANNEL (v4)	
COMMAND_CLASS_DEVICE_RESET_LOCALLY (v1)	
COMMAND_CLASS_CONFIGURATION (v1)	
COMMAND_CLASS_POWERLEVEL (v1)	
COMMAND_CLASS_NODE_NAMING (v1)	
COMMAND_CLASS_NOTIFICATION (v4)	
COMMAND_CLASS_ASSOCIATION (v2)	
COMMAND_CLASS_MULTI_CHANNEL_ASSOCIATION (v3)	
COMMAND_CLASS_ASSOCIATION_GRP_INFO (v1)	
COMMAND_CLASS_SENSOR_MULTILEVEL (v4)	
COMMAND_CLASS_SWITCH_BINARY (v1)	
COMMAND_CLASS_SWITCH_ALL (v1)	
COMMAND_CLASS_CENTRAL_SCENE (v1) (STOGGLE)	
Support/Control Mark = COMMAND_CLASS_MARK	
COMMAND_CLASS_BASIC (v1)	

For parameter 16 = 0 or 255:

- Basic Set: mapped to Binary Switch Set of relay endpoint
- Basic Get: mapped to Binary Switch Get of relay endpoint
- Basic Report: mapped to Binary Switch Report of relay endpoint

For parameter 16 = 1-204:

BASIC CC can activate/temporary deactivate internal motion sensor using for evaluating the behaviour of the lamp and groups 2 and 3. Events are, however, still transmitted to the Lifeline, and the device can be controlled via remote motion sensors. (please also follow the configuration parameter 16)

- Basic Set: enable/disable sensor function
- Basic Get: request sensor status
- Basic Report: advertise sensor status

2.5.2 Root (SLAMP)

NIF (Node Information frame)	
Listening = YES	Protocol Specific Part
Opt. Func = YES	Protocol Specific Part
Protocol Specific Part	
Basic Device Class = BASIC_TYPE_ROUTING_SLAVE (Protocol Specific Part)	
Multilevel Switch Device Class = GENERIC_TYPE_SWITCH_MULTILEVEL (SMUL)	
Binary Switch Device Class = GENERIC_TYPE_SWITCH_BINARY (SBIN)	
Multilevel Power Switch Specific Device Class = SPECIFIC_TYPE_POWER_SWITCH_MULTILEVEL (SMUL)	
Binary Power Switch Specific Device Class = SPECIFIC_TYPE_POWER_SWITCH_BINARY (SBIN)	
Binary Power Switch Specific Device Class = SPECIFIC_TYPE_POWER_SWITCH_BINARY (SPIR)	
COMMAND_CLASS_ZWAVEPLUS_INFO (v2)	
COMMAND_CLASS_ASSOCIATION (v2)	
COMMAND_CLASS_MULTI_CHANNEL_ASSOCIATION (v3)	
COMMAND_CLASS_ASSOCIATION_GRP_INFO (v1)	

NIF (Node Information frame)	
Binary Power Switch Specific Device Class = SPECIFIC_TYPE_POWER_SWITCH_BINARY (SBIN)	
COMMAND_CLASS_ZWAVEPLUS_INFO (v2)	
COMMAND_CLASS_VERSION (v2)	
COMMAND_CLASS_FIRMWARE_UPDATE_MD (v3)	
COMMAND_CLASS_MANUFACTURER_SPECIFIC (v2)	
COMMAND_CLASS_MULTI_CHANNEL (v4)	
COMMAND_CLASS_DEVICE_RESET_LOCALLY (v1)	
COMMAND_CLASS_CONFIGURATION (v1)	
COMMAND_CLASS_POWERLEVEL (v1)	
COMMAND_CLASS_NODE_NAMING (v1)	
COMMAND_CLASS_NOTIFICATION (v4)	
COMMAND_CLASS_ASSOCIATION (v2)	
COMMAND_CLASS_MULTI_CHANNEL_ASSOCIATION (v3)	
COMMAND_CLASS_ASSOCIATION_GRP_INFO (v1)	
COMMAND_CLASS_SWITCH_BINARY (v1) (SBIN)	
COMMAND_CLASS_SWITCH_MULTILEVEL (v4) (SMUL)	
COMMAND_CLASS_SCENE_ACTIVATION (v1)	
COMMAND_CLASS_SCENE_ACTUATOR_CONF (v1)	
COMMAND_CLASS_SWITCH_ALL (v1)	
COMMAND_CLASS_APPLICATION_STATUS (v1)	
COMMAND_CLASS_SENSOR_MULTILEVEL (v4)	
COMMAND_CLASS_CENTRAL_SCENE (v1) (STOGGLE)	
Support/Control Mark = COMMAND_CLASS_MARK	
COMMAND_CLASS_BASIC (v1)	

- Basic Set: mapped to Binary Switch Set (SBIN)
- Basic Get: mapped to Binary Switch Get (SBIN)
- Basic Report: mapped to Binary Switch Report (SBIN)

- Basic Set: mapped to Multilevel Switch Set (SMUL)
- Basic Get: mapped to Multilevel Switch Get (SMUL)
- Basic Report: mapped to Multilevel Switch Report (SMUL)

2.5.3 Lamp (SLAMP) / Relay (SPIR)

Endpoint 1 (SLAMP) / Endpoint 3 (SPIR)

NIF (Node Information frame)	
Listening = YES	Protocol Specific Part
Opt. Func = YES	Protocol Specific Part
Protocol Specific Part	
Basic Device Class = BASIC_TYPE_ROUTING_SLAVE (Protocol Specific Part)	
Multilevel Switch Device Class = Multilevel Switch Device Class = GENERIC_TYPE_SWITCH_MULTILEVEL (SMUL)	
Binary Switch Device Class = Binary Switch Device Class = GENERIC_TYPE_SWITCH_BINARY (SBIN)	
Binary Switch Device Class = Binary Switch Device Class = GENERIC_TYPE_SWITCH_BINARY (SPIR)	
Multilevel Power Switch Specific Device Class = SPECIFIC_TYPE_POWER_SWITCH_MULTILEVEL (SMUL)	
Binary Power Switch Specific Device Class = SPECIFIC_TYPE_POWER_SWITCH_BINARY (SBIN)	
Binary Power Switch Specific Device Class = SPECIFIC_TYPE_POWER_SWITCH_BINARY (SPIR)	
COMMAND_CLASS_ZWAVEPLUS_INFO (v2)	
COMMAND_CLASS_ASSOCIATION (v2)	
COMMAND_CLASS_MULTI_CHANNEL_ASSOCIATION (v3)	
COMMAND_CLASS_ASSOCIATION_GRP_INFO (v1)	

NIF (Node Information frame)	
COMMAND_CLASS_SWITCH_BINARY (v1) ^(S_{PIR})	
COMMAND_CLASS_SWITCH_MULTILEVEL (v4) ^(S_{MUL})	
COMMAND_CLASS_SCENE_ACTIVATION (v1) ^(S_{LAMP})	
COMMAND_CLASS_SCENE_ACTUATOR_CONF (v1) ^(S_{LAMP})	
COMMAND_CLASS_SWITCH_ALL (v1)	
COMMAND_CLASS_APPLICATION_STATUS (v1)	

Basic Set: mapped to Binary Switch Set ^(S_{PIR})
 Basic Get: mapped to Binary Switch Get ^(S_{PIR})
 Basic Report: mapped to Binary Switch Report ^(S_{PIR})

Basic Set: mapped to Binary Switch Set ^(S_{BIN})
 Basic Get: mapped to Binary Switch Get ^(S_{BIN})
 Basic Report: mapped to Binary Switch Report ^(S_{BIN})

Basic Set: mapped to Multilevel Switch Set ^(S_{MUL})
 Basic Get: mapped to Multilevel Switch Get ^(S_{MUL})
 Basic Report: mapped to Multilevel Switch Report ^(S_{MUL})

2.5.4 Motion sensor

Endpoint 2 ^(S_{LAMP}) / Endpoint 1 ^(S_{PIR})

NIF (Node Information frame)	
Listening = YES	Protocol Specific Part
Opt. Func = YES	Protocol Specific Part
Protocol Specific Part	
Basic Device Class = BASIC_TYPE_ROUTING_SLAVE (Protocol Specific Part)	
Binary Sensor Device Class = GENERIC_TYPE_SENSOR_NOTIFICATION	
Routing Binary Sensor Specific Device Class = SPECIFIC_TYPE_NOTIFICATION_SENSOR	
COMMAND_CLASS_ZWAVEPLUS_INFO (v2)	
COMMAND_CLASS_ASSOCIATION (v2)	
COMMAND_CLASS_MULTI_CHANNEL_ASSOCIATION (v3)	
COMMAND_CLASS_ASSOCIATION_GRP_INFO (v1)	
COMMAND_CLASS_NOTIFICATION (V4)	
Support/Control Mark = COMMAND_CLASS_MARK	
COMMAND_CLASS_BASIC (v1)	

BASIC CC can activate/temporary deactivate internal motion sensor using for evaluating the behaviour of the lamp and groups 2 and 3. Events are, however, still transmitted to the Lifeline, and the device can be controlled via remote motion sensors. (please also follow the configuration parameter 16)

Basic Set: enable/disable sensor function
 Basic Get: request sensor status
 Basic Report: advertise sensor status

2.5.5 Light sensor

Endpoint 3 ^(S_{LAMP}) / Endpoint 2 ^(S_{PIR})

NIF (Node Information frame)	
Listening = YES	Protocol Specific Part
Opt. Func = YES	Protocol Specific Part
Protocol Specific Part	
Basic Device Class = BASIC_TYPE_ROUTING_SLAVE (Protocol Specific Part)	
Multilevel Sensor Device Class = GENERIC_TYPE_SENSOR_MULTILEVEL	
Routing Multilevel Sensor Specific Device Class = SPECIFIC_TYPE_ROUTING_SENSOR_MULTILEVEL	
COMMAND_CLASS_ZWAVEPLUS_INFO (v2)	
COMMAND_CLASS_SENSOR_MULTILEVEL (v4)	
COMMAND_CLASS_ASSOCIATION (v2)	
COMMAND_CLASS_MULTI_CHANNEL_ASSOCIATION (v3)	
COMMAND_CLASS_ASSOCIATION_GRP_INFO (v1)	

Basic command set ignored.

2.5.6 Button ^(S_{TOGGLE})

Endpoint 4

NIF (Node Information frame)	
Listening = YES	Protocol Specific Part
Opt. Func = YES	Protocol Specific Part
Protocol Specific Part	
Basic Device Class = BASIC_TYPE_ROUTING_SLAVE (Protocol Specific Part)	
Wall Controller Device Class = GENERIC_TYPE_WALL_CONTROLLER	
Basic Wall Controller Specific Device Class = SPECIFIC_TYPE_BASIC_WALL_CONTROLLER	
COMMAND_CLASS_ZWAVEPLUS_INFO (v2)	
COMMAND_CLASS_CENTRAL_SCENE (v1)	
COMMAND_CLASS_ASSOCIATION (v2)	
COMMAND_CLASS_MULTI_CHANNEL_ASSOCIATION (v3)	
COMMAND_CLASS_ASSOCIATION_GRP_INFO (v1)	

Basic command set ignored.

2.6 Configuration

Basic Set Command value: ^(S_{MUL})

Parameter Number	Size	Range	Default
BASIC	1	1-99	99

Default light level.

Time [s]:

Parameter Number	Size	Range	Default
1 (TIME)	2	5-900	180

Duration of light after motion detection.

Light threshold [lx]:

Parameter Number	Size	Range	Default
2 (LIGHT)	2	2-2000, 0	2000 / potentiometer state (if present)

0 – run Learn ambient light sequence.

2000 – is used as daylight (always night mode).

Value can be controlled via potentiometer (if present on device) – potentiometer value is then used as the default value and any potentiometer movement rewrites the current setting.

Night dim mode and time [min]: (only for SLAMP with DIM ability)

Parameter Number	Size	Range	Default
3 (DIM)	1	0-60, -1	0 / potentiometer state (if present)

0 – off (dim = basic light completely disabled).

1-60 – time [minutes] (enabled in night mode, starts after lamp is switched off after motion detection).

-1 – whole night (dim through the whole night when lamp is off).

Dim mode is also disabled when local control is disabled as well as in Slave mode.

Motion Radar Range [cm]: (only for iHF sensor)

Parameter Number	Size	Range	Default
4 (RANGE)	2	100-500	500 / potentiometer state (if present)

Value can be controlled via potentiometer (if present on device) – potentiometer value is then used as default value and any potentiometer movement rewrites the current setting.

Motion Radar Sensitivity [%]: (SLAMP)

Parameter Number	Size	Range	Default
5 (SENSITIVITY)	1	2-100	100 / potentiometer state (if present)

Value can be controlled via potentiometer (if present on device) – potentiometer value is then used as the default value and any potentiometer movement rewrites the current setting.

Motion Radar Sensitivity [%]: (SPIR)

Parameter Number	Size	Range	Default
5 (SENSITIVITY)	1	2-100	100 / potentiometer state (if present)

Value can be controlled via potentiometer (if present on device) – potentiometer value is then used as the default value and any potentiometer movement rewrites the current setting.

Brightness measuring interval [min]: (only SLAMP)

Parameter Number	Size	Range	Default
6 (BRIGHTNES MEAS INTERVAL)	1	5-120, 0	0

Interval for measuring ambient light when lamp is on (lamp switches off briefly and measures). 0 = function is off.

Use external Ambient Light value:

Parameter Number	Size	Range	Default
8 (GLOBAL_LIGHT)	1	0/1	1

When GLOBAL_LIGHT mode is ON – device overrides its own light sensor values and uses Light Report values from any Z-Wave light sensor instead – this has to be configured appropriately to send light automatically. If the last remote light level value is older than 30 minutes, the internal light value is used again until the next external value is received.

Disable local control:

Parameter Number	Size	Range	Default
9 (SLAVE_MODE)	1	0-4, 0-0x44 (STOGGLE)	2

Bit Field:

bit	7	6	5	4	3	2	1	0
Function	-	Don't use button for lamp switching (STOGGLE)	-	-	-	"Stupid" mode	Central unit checking in slave mode	Slave mode

"Stupid" mode (bit 2 = 1):

- has higher priority then slave mode
- lamp/relay is permanently on (for simple power wall switch controlling)

Slave mode (bit 0 =1):

- only if included in Z-Wave network
- useful for controlling via third-party sensor
- lamp/relay is directly controlled via Z-Wave, internal sensors are not used for controlling it

Central unit checking (bit 1 =1): (useful especially for controlling via gateway)

When slave bit is 0:

- device signals fail of lifeline connection (if this bit is zero, fail of lifeline connection is not signalled)

When slave bit is 1:

- device checks presence of Z-Wave device in lifeline group (gateway). If it is not present for 2 minutes (testing repeatedly every 30 seconds) device switches to normal mode in the same way as after the end of local disabled mode (ON_BEHAVIOUR)
- the device checks every 1 minute for recovery of lifeline connection
- if no lifeline specified - it works in normal mode

Do not use button for lamp switching (bit 6 = 1): only for STOGGLE variant

- disables button controlling device itself along with controlling group 5. When enabled also works in stand-alone.

Be careful with this option, device stops using its own motion sensor in Slave and "Stupid" mode.

Off behaviour (timeout):

Parameter Number	Size	Range	Default
10 (OFF_BEHAVIOUR)	2	0 – 209, 255	10

Behaviour after BASIC OFF (and similar commands).

If a transition (even with zero change) with a non-default duration is to be processed, the transition cannot be interrupted by any motion event in any case.

0	Lamp/Relay is switched off and remains so until any new motion event (local or remote) is received.
1 - 209	Lamp/Relay is switched off and remains so until after a specified timeout once a new motion event (local or remote) is received. Timeout: 1..100 – 1 second (1) to 100 seconds (100) in 1-second resolution 101..200 – 1 minute (101) to 100 minutes (200) 1-minute resolution 201..209 – 1 hour (201) to 9 hours (209) in 1-hour resolution
210 - 254	Reserved
255	Lamp/relay is switched off for TIME (cfg 1). It does not wait for a motion event and works normally via current motion evaluation.

On behaviour (timeout):

Parameter Number	Size	Range	Default
11 (ON_BEHAVIOUR)	2	0 – 209, 255	255

Behaviour after BASIC ON (and similar commands).

If a transition (even with zero change) with a non-default duration is to be processed, the transition cannot be interrupted by any motion event in any case.

0	Lamp/relay is switched on and remains so until any new motion event (local or remote) is received. It then works normally via current motion evaluation. Notice – during the day, this mode cannot be ended remotely due to motion events not being transmitted – only via local motion sensor if enabled.
1 - 209	Lamp/relay is switched on and remains so until after a specified timeout once a new motion event (local or remote) is received. It then works normally via current motion evaluation. Timeout: 1..100 – 1 second (1) to 100 seconds (100) in 1-second resolution 101..200 – 1 minute (101) to 100 minutes (200) in 1-minute resolution 201..209 – 1 hour (201) to 9 hours (209) in 1-hour resolution Notice – during the day, this mode cannot be ended remotely due to motion events not being transmitted – only via local motion sensor if enabled.
210 - 254	Reserved
255	Lamp/relay is switched on for TIME (cfg 1). It does not wait for a motion event and works normally via current motion evaluation.

On behaviour time over (timeout):

Parameter Number	Size	Range	Default
12 (ON_TIME_OVER)	2	0 – 209, 255	204

Time limit to stop waiting for motion after timeout of ON_BEHAVIOUR or OFF_ON_BEHAVIOUR (0-209) to prevent staying ON forever when there is no motion.

0	No additional waiting for motion.
1 - 209	1..100 – 1 second (1) to 100 seconds (100) in 1-second resolution 101..200 – 1 minute (101) to 100 minutes (200) in 1-minute resolution 201..209 – 1 hour (201) to 9 hours (209) in 1-hour resolution
210 - 254	Reserved
255	Never stop waiting for motion.

Sequence On-Off behaviour (timeout):

Parameter Number	Size	Range	Default
13 (ON_OFF_BEHAVIOUR)	2	0 – 209,255	204

Behaviour after a rapid sequence of BASIC ON and BASIC OFF commands. The intention is to use a much longer timeout value than the time after a single ON command which should then be followed by a short timeout value. The behaviour is the same as for parameter 10 (OFF_LOCAL_DISABLE) except: 255 – device ignores ON - OFF sequence and uses OFF behaviour.

Sequence Off-On behaviour (timeout):

Parameter Number	Size	Range	Default
14 (OFF_ON_BEHAVIOUR)	2	0 – 209, 255	204

Behaviour after a rapid sequence of BASIC OFF and BASIC ON commands. The intention is to use a much longer timeout value than the time after a single OFF command which should then be followed by a short timeout value. The behaviour is the same as for parameter 11 (ON_LOCAL_DISABLE) except: 255 – device ignores OFF - ON sequence and uses ON behaviour.

Sequence timing:

Parameter Number	Size	Range	Default
15 (SEQUENCE_TIME)	1	10 – 50	10

Time in [100 milliseconds] of maximum delay between BASIC ON and BASIC OFF (and vice versa) to consider this as a sequence. It is typically 1 second, but can be exceptionally longer due to retransmissions and overload – in this case, a longer interval can be allowed (up to 5 seconds).

Motion Off behaviour (timeout):

Parameter Number	Size	Range	Default
16 (MOTION_DISABLE)	2	0 – 209, 255	0

Motion disable timeout after BASIC SET to motion endpoint when the internal motion sensor is not used for evaluating the behaviour of the lamp^(SLAMP) relay^(SPIR) and groups 2 and 3. Events are, however, still transmitted to the Lifeline, and the device can be controlled via remote motion sensors.

0	BASIC SET to motion sensor endpoint ignored, BASIC to root is mapped to relay endpoint, ^(SPIR) motion sensor still enabled
1 - 209	Internal motion sensor is disabled for specified timeout after BASIC SET 0x00 to motion endpoint. Timeout: 1..100 – 1 second (1) to 100 seconds (100) in 1-second resolution 101..200 – 1 minute (101) to 100 minutes (200) in 1-minute resolution 201..209 – 1 hour (201) to 9 hours (209) in 1-hour resolution
210 - 254	Reserved
255	BASIC SET to motion endpoint ignored, motion sensor still disabled.

3 DEVICE USE

3.1 Basic Z-Wave functions

There is a link key on the device which is used to perform the inclusion, exclusion and reset functions. When power is applied for the first time, the device has not yet been assigned with a node ID and cannot yet work with other Z-Wave devices. The device is configured to work as a stand-alone device.

Action/ Stat.	Description
No node ID	The controller does not allocate a node ID to the device. The device works as a stand-alone device. The light sensor is internally mapped to Night mode input. The motion sensor is internally mapped to Switch input.
Inclusion*	1. Set the Z-Wave controller to inclusion mode. 2. Press the link key once briefly to set the device to inclusion mode. 2. Turn the knob from 0 to SET for max. 5 seconds and back. ^(SKNOB) 2. Press the link key 3x briefly to set the device into inclusion mode. ^(STOGGLE)
Exclusion*	1. Set the Z-Wave controller to exclusion mode. 2. Press the link key once briefly to set the device to exclusion mode. 2. Turn the knob from 0 to SET for max. 5 seconds and back. ^(SKNOB) 2. Press the link key 3x briefly to set the device into exclusion mode. ^(STOGGLE)
Reset	(This procedure should only be used when the network primary controller is inoperable.) 1. Press the link key once briefly. 2. Within 1 second of step 1, press the link key again and hold it down for longer than 5 seconds. 3. Node ID is excluded. The device reverts to the factory default state. 1. Press the link key 3x briefly 2. Within 1 second of step 1, press the link key again and hold it down for longer than 5 seconds. 3. Node ID is excluded. The device reverts to the factory default state. ^(STOGGLE) 1. Turn the knob from 0 to SET for max 5 seconds and back. 2. Node ID is excluded. The device reverts to the factory default state. ^(SKNOB)
* Failed or successful node ID inclusion/exclusion events can be viewed on the controller.	

3.2 Intended use of system

Association groups must be managed by Association or Multichannel association command class.

Settings must be correctly set by Configuration command class.

3.2.1 Ambient light

NIGHT_MODE is calculated by each device by comparing the lux level with the threshold parameter 2 (LIGHT). For this reason, the LIGHT parameter should be set to the same value and one source of lux level should be used by all devices in a group; the use of potentiometers is therefore not recommended for light threshold settings unless a limit value (default) is used. When a valid remote lux level is used in the device and the light teach mode is triggered, this value is used as the threshold. This method can be used to standardise the light thresholds of all devices in a group.

Using one central source of ambient light is strongly recommended. This can be a Steinel device (with optimum light conditions, e.g. near a window), but a better choice is to use a device without its own light source as a stand-alone PIR sensor; a good option is an ASTRO module in the gateway that calculates night time from coordinates and the precise time (and set to send 0 lux at night / 2000 lux during the day). Any Z-Wave light sensor that can send multilevel reports with measured light to associated devices can also be used.

To allow remote lux level use, set configuration parameter 8 (GLOBAL_LIGHT) to 255. This is the default setting. Use only one device as master to control light externally.

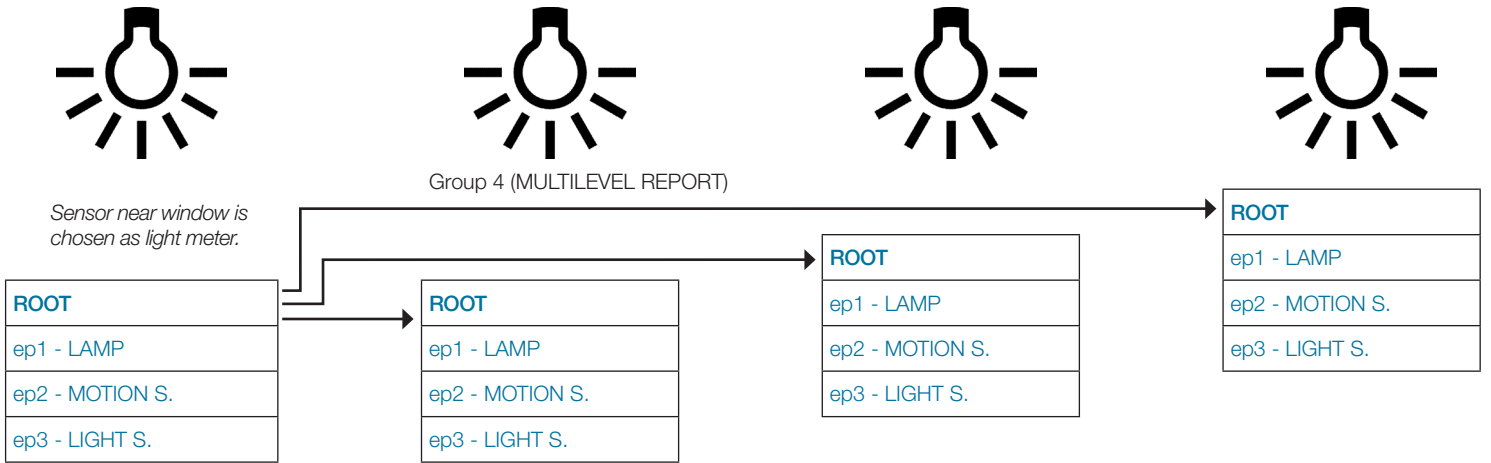

Some third-party sensors can only send the lux level to one device; devices can then resend this value further:

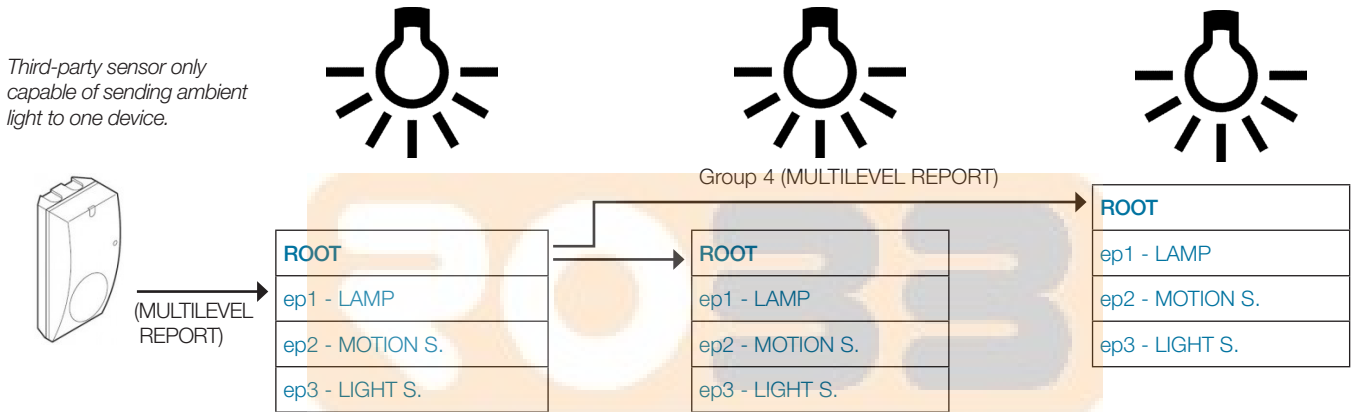

DÉ DOMOTICA SHOP

3.2.2 Motion events

The system is designed to cooperate in the detection of motion. Motion detection events control the relay when LOCAL_DISABLED = 0 and NIGHT_MODE = ON.

- After the first motion detection event, the MOTION_BEGIN frame is sent and the relay is turned on. If motion continues to be detected every 1 minute (Repeat_timeout), MOTION_BEGIN is sent again. Once motion is no longer detected, MOTION_END is sent 5 seconds (Motion_timeout) after the last motion detection.
- Each relay receives all MOTION_BEGIN and MOTION_END frames and remembers the state of all relays that sent it a MOTION_BEGIN frame. Upon receipt of MOTION_END or timeout after 2 minutes (Malfunction_Off_timeout) without any MOTION_BEGIN frame, the device will be removed from the list.
- If there is no movement detection internally or in the remote movement table, the Switch_Off_timeout begins to count down; this can be interrupted by a new motion event.
- Once the Switch_Off_timeout time has expired, the relay is turned off.

Example of a cooperating system:

Six lamps in corridor, configured so that each of them controls its neighbors only:

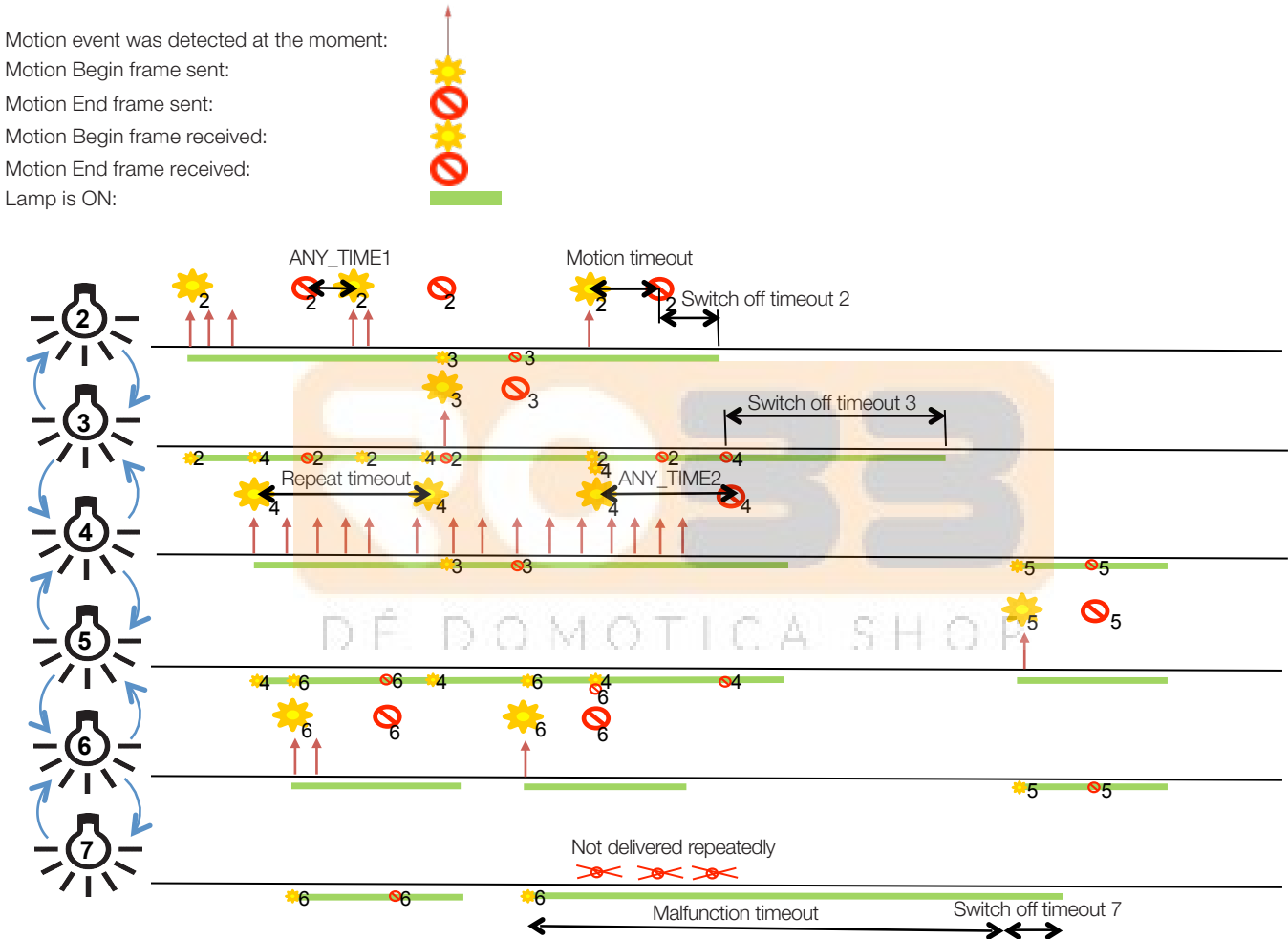

- Motion timeout = 5 seconds (system constant)
- Switch off timeout = 0 seconds – 30 minutes (will normally be equal in whole lamp group)
- Repeat timeout = 1 minute (must be >=30 seconds)
- Malfunction timeout = 2 minutes and 10 seconds
- (Must be >= Repeat timeout + Motion timeout + reserve to deliver)
- ANY_TIME1...can be any value from 0...infinity
- ANY_TIME2...range within these limits: Motion timeout >= ANY_TIME2 < Repeat timeout
- Switch_Off_timeout = TIME - Motion_timeout

3.2.2.1 Setting up motion detection groups

Legacy root – root association should be used whenever possible. Multichannel encoding is only supported for third-party devices that are not able to use root endpoint.

Motion detection association in a group of mutually cooperating devices: (e.g. each device lights itself and its neighbor)

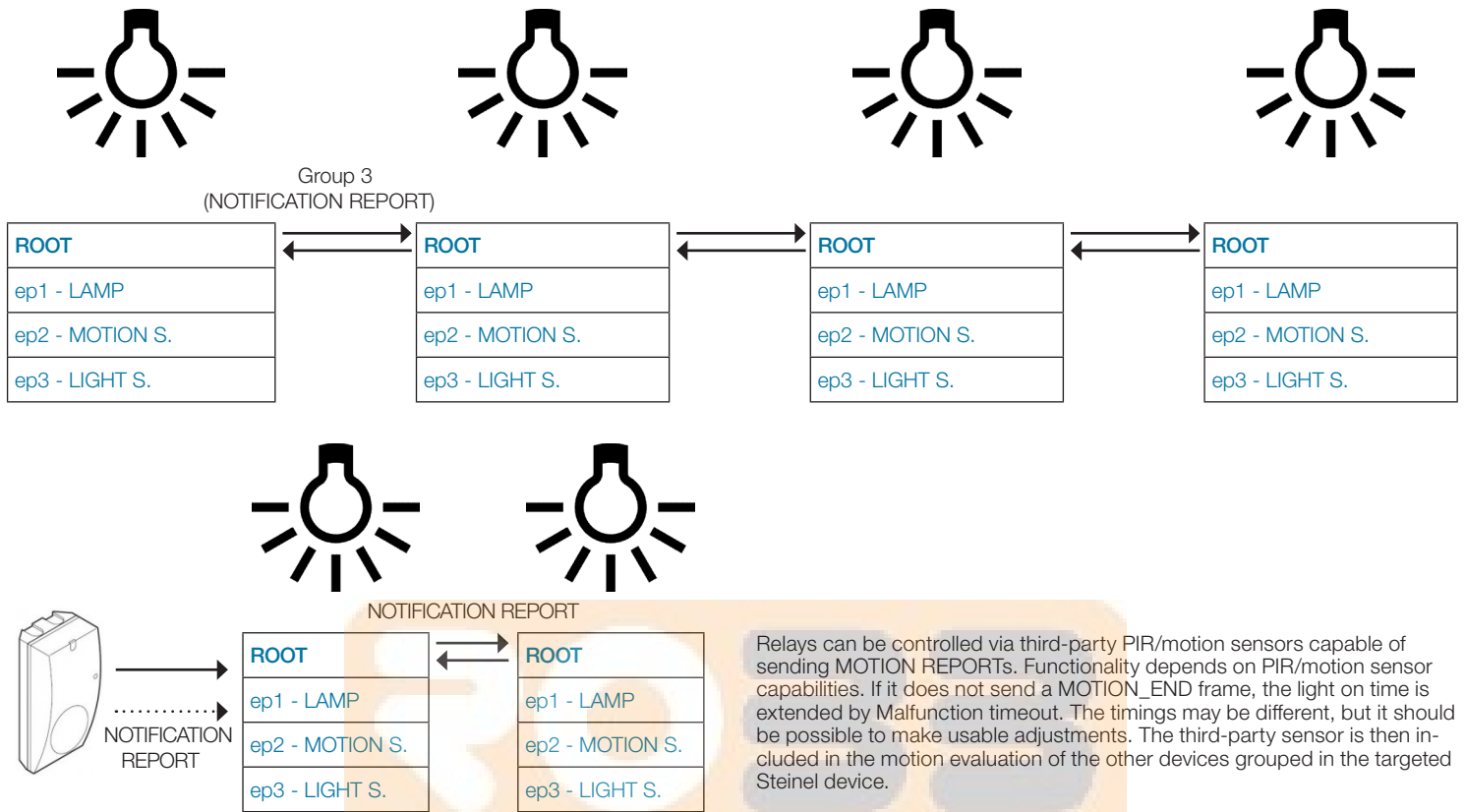

DE DOMOTICA SHOP

3.2.3 Direct control function

Any device can be attached to a Steinel device and controlled via BASIC SET commands through the evaluation of movement and light, as with internal use (so that all of these devices work together). This is intended for third-party devices without MOTION REPORT capability.

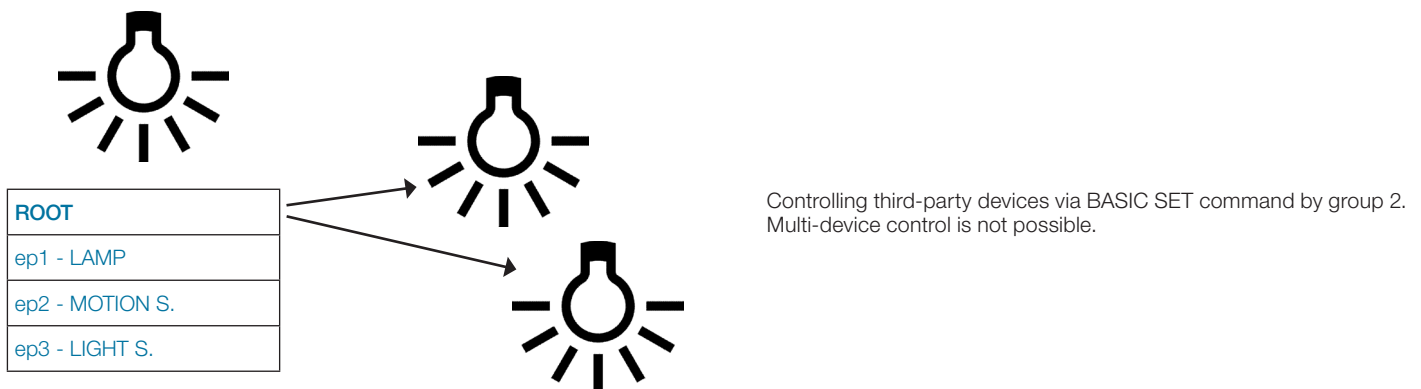

3.2.4 Control via common Z-Wave commands

The relay can be controlled via BASIC SET (and similar commands). In this case, local control is disabled for a set time (user or other device takes over control of the relay). Timeouts are defined in the configuration parameters 10 (OFF_LOCAL_DISABLE) and 11 (ON_LOCAL_DISABLE). For Slave function configuration, parameter 9 (SLAVE_MODE) should be set.

Direct controlling lamp by gateway/central unit:

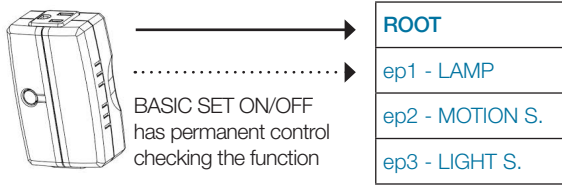

Local lamp control should be disabled permanently by configuring parameter 9 (SLAVE_MODE) = 3. Lamp is then in slave mode. Controlling logic is in gateway/central device.

Direct control of relay via third-party sensor without capability of associating Steinel devices to the movement notification command:

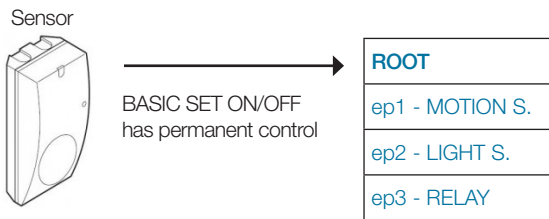

Local lamp control should be disabled permanently by configuring parameter 9 (SLAVE_MODE) = 1. Lamp is then in slave mode. It should only be controlled by one sensor via BASIC SET. Cooperative motion evaluation is not used in this configuration.

Controlling devices via third-party wall-switch or remote controller:

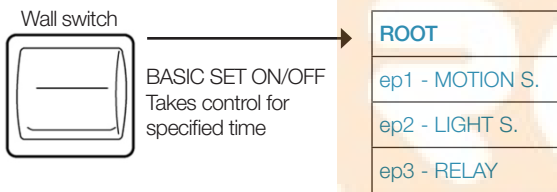

Parameters 10 (OFF_LOCAL_DISABLE) and 11 (ON_LOCAL_DISABLE) should be configured to suit the functionality of the system.

3.2.5 Motion sensor inactivity and local disable possibilities

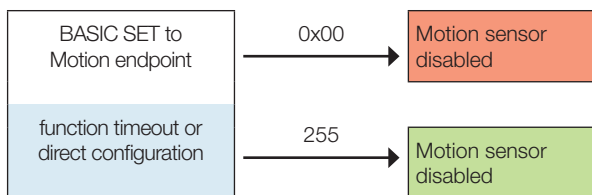

Motion sensor disabled - means that the internal motion sensor does not control the relay and does not send motion events to group 3, but still sends motion events to lifeline, and the device can be controlled by other devices. Dim mode is allowed. Light is sent normally to group 4 and local state to group 2.

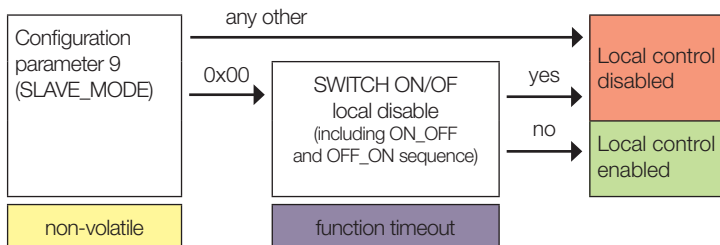

Local control disabled – means that internal and external motion events do not control the relay or ambient light level so Dim mode is also disabled. The relay can only be controlled via Z-Wave commands, but motion events are still sent to group 3 and lifeline. Light is sent to group 4 and local state is sent to group 2.

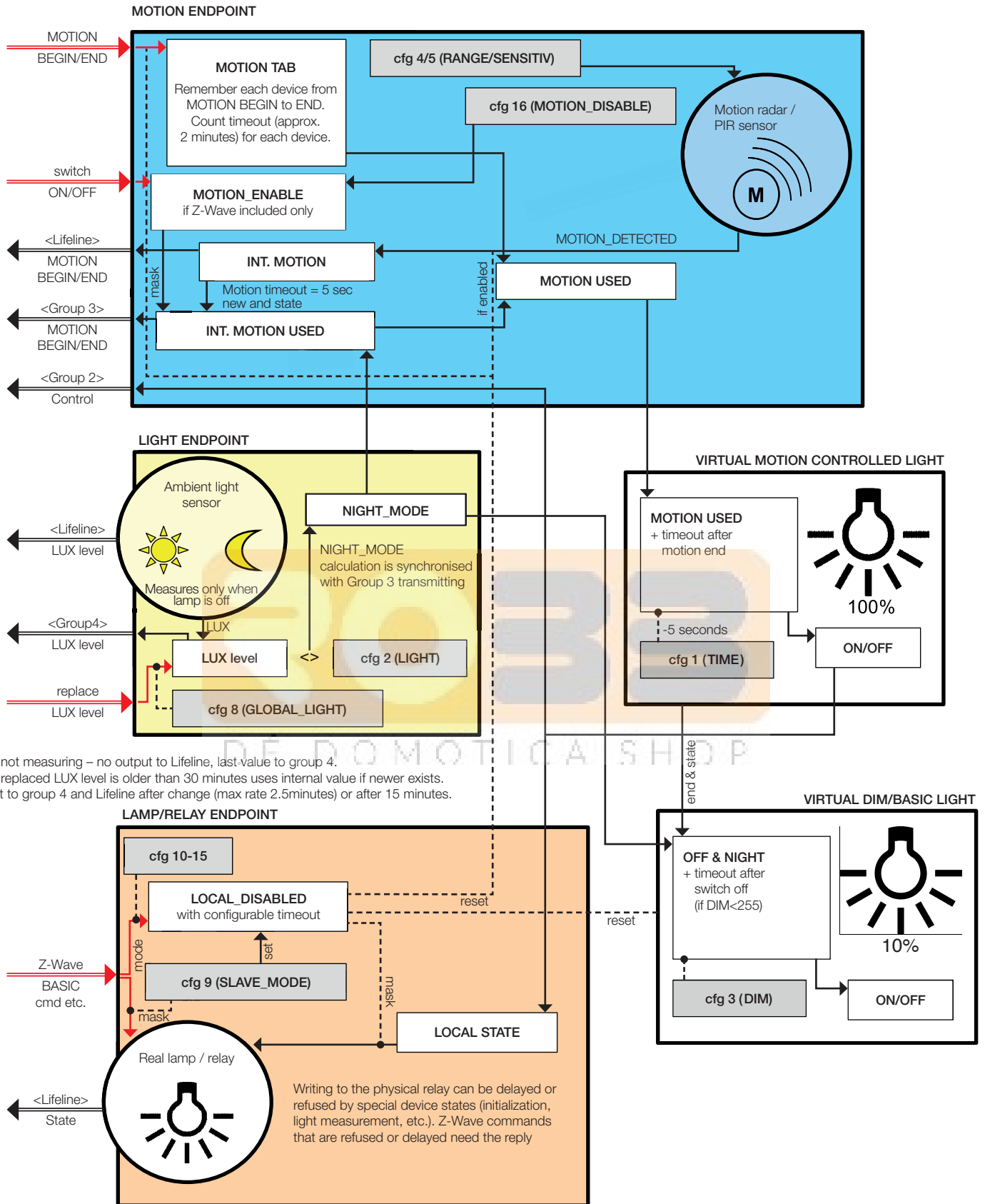

3.2.6 Manual override functions

Settings used for manual override functions:

10 OFF_LOCAL_DISABLE	Should be set to 255, 0 or low value in seconds (default 10 = 10 seconds) This is used to end override mode before timeout and continue OFF
11 ON_LOCAL_DISABLE	Should be set to 255, 0, or low value in seconds (default 255 = just switch on) This is used to end override mode before timeout and continue ON
12 ON_TIME_OVER	Should be set to the corresponding value depending on application.
13 ON_OFF_LOCAL_DISABLE	Should be set to required timeout (default 204 = 4 hours) This is used to start override mode OFF
14 OFF_ON_LOCAL_DISABLE	Should be set to required timeout (default 204 = 4 hours) This is used to start override mode ON
15 SEQUENCE_TIME	Should be tested in network configuration (default 10 = 1 second)

Manual override controlled via wall switch or remote controller using ON/OFF sequence:

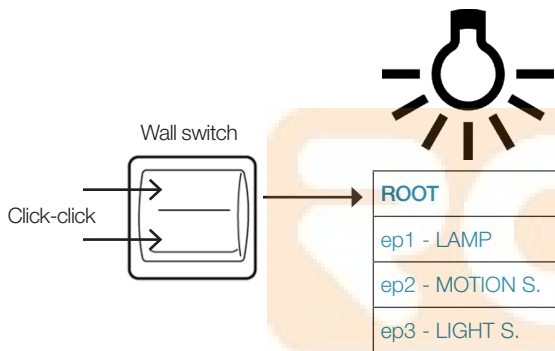

Override ON function causing a blink:
 1. Send BASIC OFF
 2. Then send BASIC ON in quick succession
 3. To end override mode before timeout, send BASIC ON or BASIC OFF

Override OFF function causing a blink:
 1. Send BASIC ON
 2. Then send BASIC OFF in quick succession
 3. To end override mode before timeout, send BASIC ON or BASIC OFF

On/Off sequence causes a blink during mode initialization.
 Device still controls devices in groups 2 and 3, so all lamps to be overridden also have to be switched.

Manual override controlled by disabling of motion sensor:

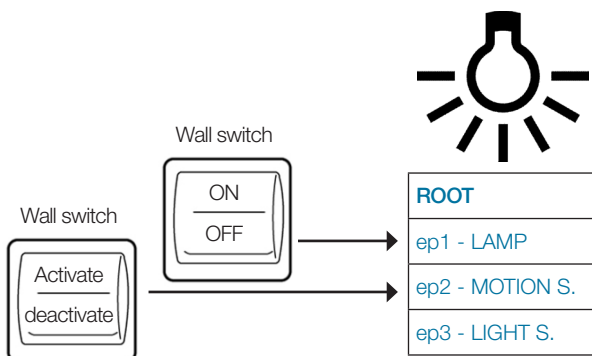

Override function – direct wall switch control:
 1. Send BASIC OFF to motion sensor endpoint
 2. It is possible to control the device when required by BASIC SET ON/OFF
 3. To end override mode before timeout, send BASIC ON to motion sensor endpoint

Using direct sensor control does not cause a blink during mode initialization.
 All devices controlling the specified device(s) have to be disabled. OFF_LOCAL_DISABLE and ON_LOCAL_DISABLE timeouts should be set to a short period, so they do not to affect the system inadvertently (MOTION_ENABLE and LOCAL_DISABLE functions work independently).

3.3 Special functions

3.3.1 Security System function

Steinel device with motion sensor can be an element of home security system, using motion notifications. Motion notifications to lifeline are sent also by day (when NIGHT_MODE is off) and regardless of any lamp settings and state. Note that lamp motion sensors are intended for lamp controlling especially so they are quick but not as resistant to false alarm at a high level of sensitivity. Also there is no power backup. Gateway must also evaluate notifications.

3.3.2 "Light Teach" function

Implementation by direct setting of light (not recommended method):
 1) Read actual Light value
 2) Set configuration parameter 2 (LIGHT) remotely

Implementation with light teach function (recommended):
 Teach function is triggered by configuring parameter 2 (LIGHT) = 0. After precise firmware measurement of the current value of ambient light (special procedure), parameter 2 (LIGHT) is updated.

3.3.3 "Slow light ramp up and down" function

Can be implemented in lamp, multilevel lamps can also be controlled via Z-Wave.

Binary lamps can have a static, factory-defined light ramp up and down speed. After switch on, the light intensity increases slowly and after switch off, decreases slowly. The Z-Wave system does not consider the light ramp speed in binary mode. ^(SBI^N)

Multilevel lamps use this ramp for commands without duration such as BASIC SET, MULTILEVEL SWITCH without duration and SCENE_ACTIVATION_SET with default duration. The ramp speed can, however, also be controlled via standard Z-Wave commands. Firmware-defined ramp up and down speeds can be different. ^(SMUL^L)