



MCOHome

Z-Wave Glass surface touch panel switch

SKU: MCO_TPS411

Quickstart

This is a **On/Off Power Switch** for **Europe**. To run this device please connect it to your mains power supply.

A This device is a Z-Wave Actuator. To include or exclude the device you only need to press and hold any key for 8 seconds.

What is Z-Wave?

Z-Wave is the international wireless protocol for communication in the Smart Home. This device is suited for use in the region mentioned in the Quickstart section. (For more information about frequency regulations please refer to [the frequency coverage overview at Sigma Designs Website](#)).

Z-Wave ensures a reliable communication by reconfirming every message (**two-way communication**) and every mains powered node can act as a repeater for other nodes (**meshed network**) in case the receiver is not in direct wireless range of the transmitter.

This device and every other certified Z-Wave device can be **used together with any other certified Z-Wave device regardless of brand and origin** as long as both are suited for the same frequency range.

If a device supports **secure communication** it will communicate with other devices secure as long as this device provides the same or a higher level of security. Otherwise it will automatically turn into a lower level of security to maintain backward compatibility.

For more information about Z-Wave technology, devices, white papers etc. please refer to www.z-wave.info.



Product Description

The MCO_TPS411 is a glass-surface wireless actuator able to switch a load up to 1100 W. It is designed for application in UK Pattress boxes (according to British Standard). Beside local switching the device can be used to control two groups of directly associated devices or scenes stored in the central controller. A blue LED on every button indicates the switching status. The installation of the device requires a 3 wire system with neutral wire.

Prepare for Installation / Reset

Please read the user manual before installing the product.

In order to include (add) a Z-Wave device to a network it **must be in factory default state**. Please make sure to reset the device into factory default. You can do this by performing an Exclusion operation as described below in the manual. Every Z-Wave controller is able to perform this operation however it is recommended to use the primary controller of the previous network to make sure the very device is excluded properly from this network.

Safety Warning for Mains Powered Devices

ATTENTION: only authorized technicians under consideration of the country-specific installation guidelines/norms may do works with mains power. Prior to the assembly of the product, the voltage network has to be switched off and ensured against re-switching.

Installation

Important: Please make sure you have cut off power supply before you start to install the device.

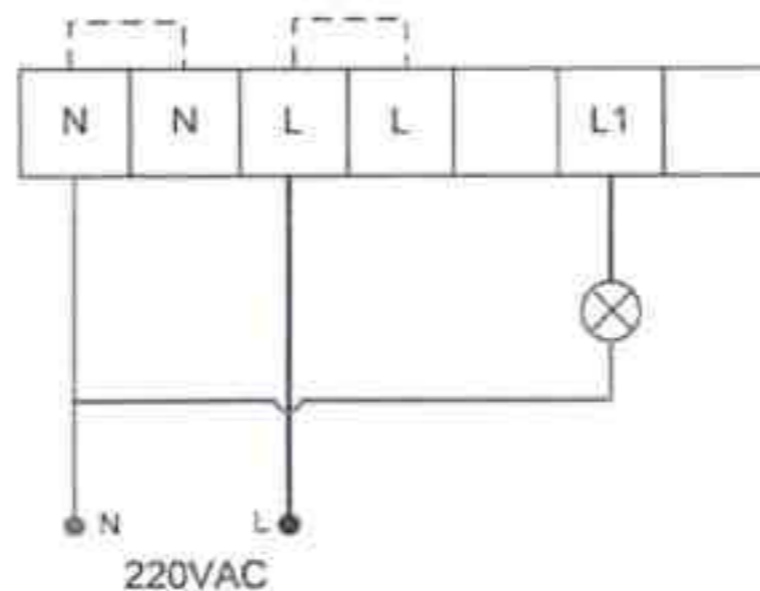

- Connect Hot Line to "L"
- Connect Neutral Line to "N"
- Connect Load wire to "L1"

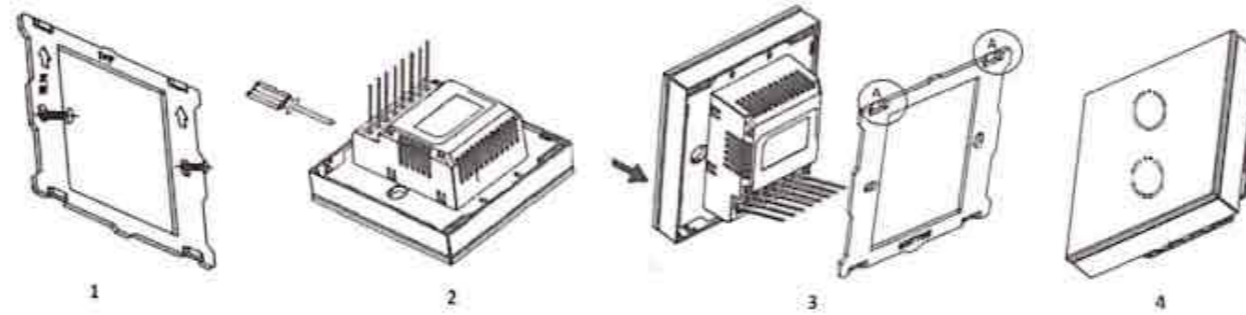

1. Remove the steel frame from the device, and secure it onto the junction box with two screws.
2. Insert all wires into the right terminals and tighten screws.
3. Attach the wired device on "A" points of the steel frame as shown first, and then push the whole device into junction box.
4. Confirm the device is well mounted, power on and it is ready to operate.

Inclusion/Exclusion

On factory default the device does not belong to any Z-Wave network. The device needs to be **added to an existing wireless network** to communicate with the devices of this network. This process is called **Inclusion**.

Devices can also be removed from a network. This process is called **Exclusion**. Both processes are initiated by the primary controller of the Z-Wave network. This controller is turned into exclusion respective inclusion mode. Inclusion and Exclusion is then performed doing a special manual action right on the device.

Inclusion

To include the device you only need to press and hold any key for 8 seconds.

Exclusion

To exclude the device you only need to press and hold any key for 8 seconds.

Product Usage

The actuator is operated by the local switching Touch panels or wirelessly using Z-Wave commands.

Quick trouble shooting

Here are a few hints for network installation if things don't work as expected.

1. Make sure a device is in factory reset state before including. In doubt exclude before include.
2. If inclusion still fails, check if both devices use the same frequency.
3. Remove all dead devices from associations. Otherwise you will see severe delays.
4. Never use sleeping battery devices without a central controller.
5. Don't poll FLIRS devices.
6. Make sure to have enough mains powered device to benefit from the meshing

Association - one device controls another device

Z-Wave devices control other Z-Wave devices. The relationship between one device controlling another device is called association. In order to control a different device, the controlling device needs to maintain a list of devices that will receive controlling commands. These lists are called association groups and they are always related to certain events (e.g. button pressed, sensor triggers, ...). In case the event happens all devices stored in the respective association group will receive the same wireless command wireless command, typically a 'Basic Set' Command.

Association Groups:

Group Number	Maximum Nodes	Description
1	5	Switch Button Group 1
3	1	all Status Reports

Technical Data

Device Type	On/Off Power Switch
Generic Device Class	Binary Switch
Specific Device Class	Binary Power Switch
Firmware Version	01.00
Z-Wave Version	03.43
Z-Wave Product Id	015f.3102.0202

Supported Command Classes

- Switch Binary
- Switch All
- Multi Channel
- Manufacturer Specific
- Association
- Version
- Multi Channel Association
- Basic

Controlled Command Classes

- Multi Channel
- Basic

Explanation of Z-Wave specific terms

- **Controller** — is a Z-Wave device with capabilities to manage the network. Controllers are typically Gateways, Remote Controls or battery operated wall controllers.
- **Slave** — is a Z-Wave device without capabilities to manage the network. Slaves can be sensors, actuators and even remote controls.
- **Primary Controller** — is the central organizer of the network. It must be a controller. There can be only one primary controller in a Z-Wave network.
- **Inclusion** — is the process of adding new Z-Wave devices into a network.
- **Exclusion** — is the process of removing Z-Wave devices from the network.
- **Association** — is a control relationship between a controlling device and a controlled device.
- **Wakeup Notification** — is a special wireless message issued by a Z-Wave device to announce that it is able to communicate.
- **Node Information Frame** — is a special wireless message issued by a Z-Wave device to announce its capabilities and functions.

(c) 2016 Z-Wave Europe GmbH, Antonstr. 3, 09337 Hohenstein-Ernstthal, Germany, All rights reserved, www.zwave.eu. The template is maintained by [Z-Wave Europe GmbH](#). The product content is maintained by [Z-Wave Europe GmbH](#), Supportteam, support@zwave.eu. Last update of the product data: 2017-06-13 11:11:47

