

Door/Window Contact Z-Wave Plus

Installation and Operation Guide



Content

1	Delivery Scope	3	8	Z-Wave	10
2	Safety and Warning Instructions	4	9	Association	11
3	Intended Use	5	10	Configuration	11
4	Product Description	5	11	Notification	11
5	Operating the Device	6	12	Help	12
5.1	Button	6			
5.2	LEDs	6	13	Cleaning	13
6	Commissioning	7	14	Technical Specifications	13
6.1	Inserting Batteries	8			
6.2	Add to a Z-Wave Network	8	15	Disposal	13
6.3	Remove from a Z-Wave Network	8			
6.4	Mounting of the Door/Window Contact	9	16	Warranty	14
6.5	Placing the Door/Window Contact	9			
6.6	Factory Reset	9	17	Support and Contact Information	14
7	General Configuration	10			

2. Safety and Warning Instructions

NOTE! This signal word warns of possible material damage.

WARNING!

This signal word indicates a hazard with a medium degree of risk which, if not avoided, may result in death or serious injury.

SAFETY INSTRUCTIONS

- The Door/Window Contact Z-Wave Plus is designed for use in buildings.
- Operate the Door/Window Contact Z-Wave Plus only as described in the Installation and Operation Guide.
- Do not keep using the device when there is obvious damage.
- The Door/Window Contact Z-Wave Plus may not be rebuilt, modified or opened.

WARNING! RISK OF EXPLOSION!

Improper handling of batteries can lead to explosion.

- Do not heat batteries and do not throw batteries into an open fires.
- Do not place batteries in direct sunlight.
- Protect batteries from excessive heat.
- Do not short-circuit the batteries.
- Never attempt to charge non-rechargeable batteries.
- Never disassemble batteries.
- Do not use new and used batteries together.
- Observe the correct polarity (+/-) when inserting the batteries.
- Before inserting the battery, clean the battery and the contacts in the Door/Window Contact.

WARNING! RISK OF ACID BURNS!

Leaking battery acid can lead to burns.

- Avoid contact of battery acid with skin, eyes and mucous membranes.
- In case of contact with battery acid, rinse the affected areas immediately with plenty of clear water and consult a doctor.

WARNING! RISK OF INJURY!

Risk of fatal injury and accidents to infants and children! The packaging material represents a risk of suffocation. Never leave children unattended when the packaging material is nearby. Children often underestimate the risks involved. Always keep children away from the packaging material. The device is not a toy.

3. Intended Use

The Eurotronic Door/Window Contact Z-Wave Plus is a battery powered wireless binary sensor for detecting the door or window open/closed position. The device uses an optical sensor for the status detection.

For reasons of safety and approval (CE), you must not modify and/or alter the product. If you use the product for purposes other than those described, the product may be damaged. In addition, improper use may result in hazards such as short circuits, fire, electric shock, etc.

Read the installation and operation guide carefully and keep them in a safe place. Only pass the product on to third parties together with the operating instructions.

4. Product Description

The Eurotronic Door/Window Contact Z-Wave Plus is a battery powered wireless binary sensor for detecting the door or window open/closed position. The device uses an optical sensor for the status detection.

- Intelligent Door/Window Contact with the radio standard Z-Wave
- Detects open/closed windows and doors
- Status retrieval via smartphone or tablet (via your Z-Wave controller)
- Informs you about open/closed windows/doors from anywhere
- In case of unexpected opening of a window or door (e.g. burglary) you will be informed directly via smartphone/tablet
- Starts scenes or switches devices when e.g. a door or window is opened
- Closes heating valve (e.g. Eurotronic Spirit Z-Wave Plus) when window is open to save energy



5. Operating the Device

5.1 Button

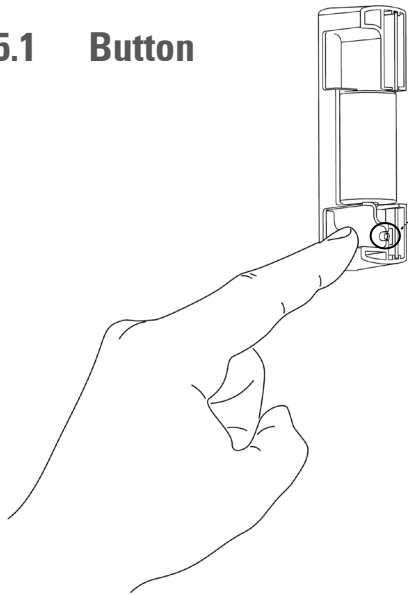

Note: To use the low push button in the housing of the Door/Window Contact, use a paper clip or a similar thin item.

Button	State	Meaning
Network-Button	Press the button three times in quick succession.	Join or leave a Z-Wave network.
Network-Button	Keep button pressed for 10 seconds.	Reset door/window contact to factory settings.

5.2 LEDs

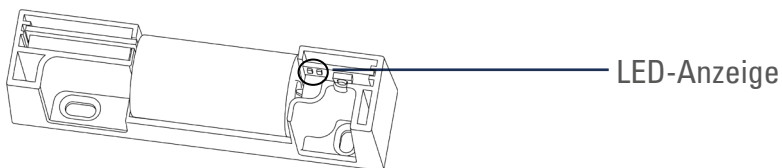

Colour	State	Meaning
Green	blinking	Network operation (join or leave) is executed.
Green	lights up for 5 seconds	A task was completed successfully.
Red	lights up for 5 seconds	A task has failed or has not ended successfully.
2 x Red, 3 x Green	light up one after the other	Factory reset was successful. Factory settings have been restored.
3 x Red	blinking	Battery is insufficient. Replace the battery.

6. Commissioning

On factory default the device does not belong to any Z-Wave network. The Door/Window Contact Z-Wave Plus needs to be added to an existing Z-Wave network to communicate with the devices of this network. This process is called Inclusion.

The Door/Window Contact Z-Wave Plus can also be removed from a Z-Wave network. This process is called Exclusion. Both processes are initiated by the primary controller of the Z-Wave network. This controller is turned into exclusion respective inclusion mode. Consult the installation and operation guide of your Z-Wave controller in order to find out how to activate the Inclusion or Exclusion mode of your Z-Wave controller.

If the Door/Window Contact Z-Wave Plus has been added to a network, it has to be removed prior to be added to another wireless network.

Interoperability

This product can be operated in any Z-Wave network with other Z-Wave certified devices from other manufacturers. All non-battery operated nodes within the network will act as repeaters regardless of vendor to increase reliability of the network.

Security

The Door/Window Contact Z-Wave Plus supports secure communication. The Door/Window Contact Z-Wave Plus will communicate with other devices secure as long as this device provides the same or a higher level of security. Otherwise the Door/Window Contact Z-Wave Plus will automatically turn into a lower level of security.

Note:

A Security Enabled Z-Wave Controller must be used to fully utilize the Door/Window Contact Z-Wave Plus.

6.1 Inserting Batteries

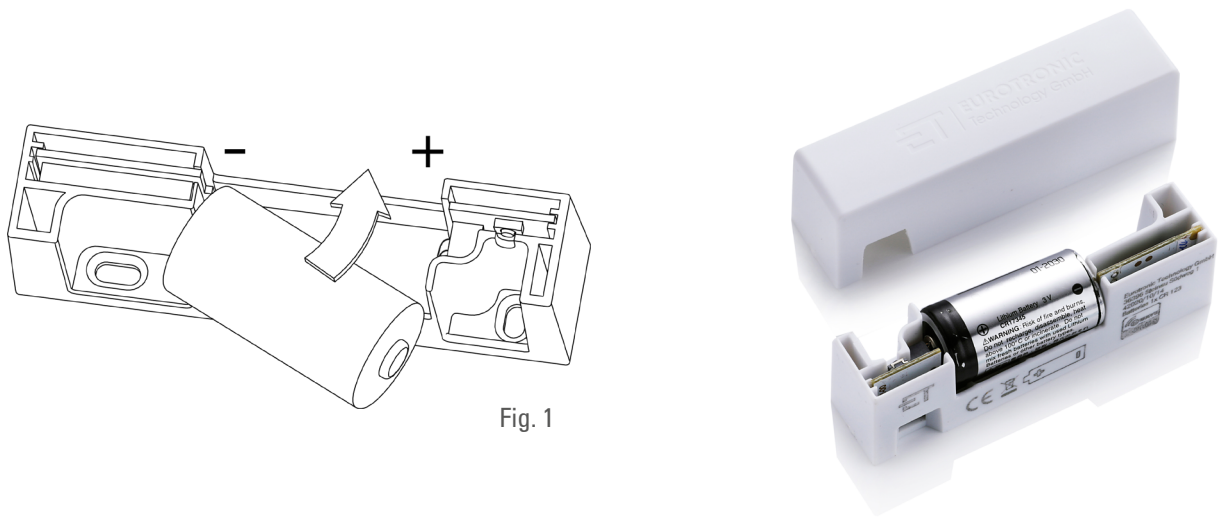

1. Open the housing of the Door/Window Contact .
2. Insert the battery into the housing. When inserting the battery, make sure that you insert the battery sideways (Fig. 1).

6.2 Add to a Z-Wave Network (Inclusion)

Start the inclusion mode of your primary Z-Wave controller .

Press the button within the housing of your Door/Window Contact **three times in quick succession** in order to activate the inclusion mode. While the inclusion mode is active, the green LED is blinking. The joining attempt takes approx. 30 seconds.

If the inclusion was successful, the green LED lights up for 5 seconds. Otherwise, the red LED light up for 5 seconds to indicate failure.

6.3 Remove from a Z-Wave Network (Exclusion)

Start the exclusion mode of your primary Z-Wave controller.

Press the button within the housing of your Door/Window Contact **three times in quick succession** in order to activate the exclusion mode. During the attempt to leave the network, the green LED is blinking.

If the exclusion was successful, the green LED light up for 5 seconds. Otherwise, the red LED lights up for 5 seconds to indicate failure.

Note: When removing (Exclusion), the configuration of the device is kept. Only the network is exited.

6.4 Mounting of the Door/Window Contact

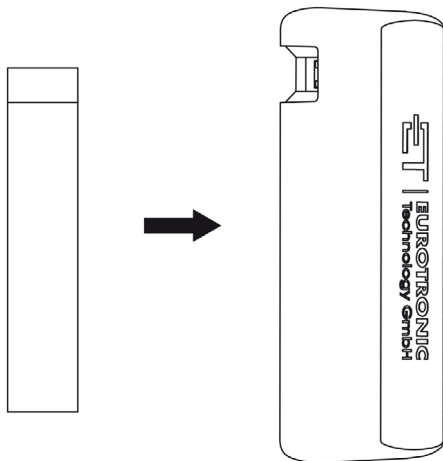

Use the adhesive strip to mount the device on the wall or the window frame.

6.5 Placing the Door/Window Contact

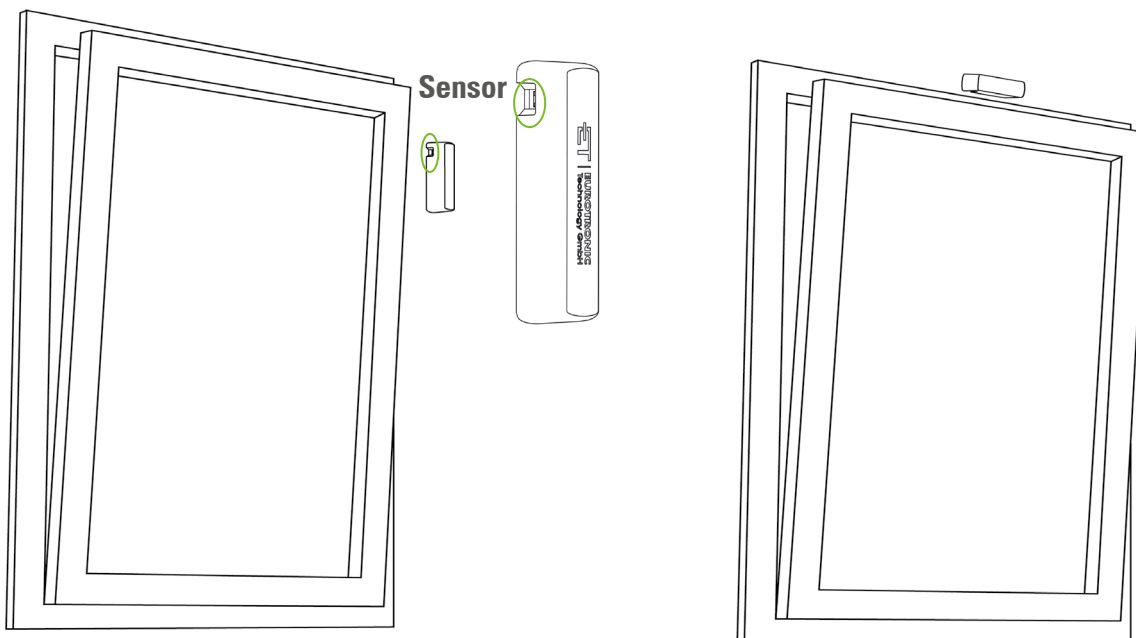

Select a suitable place for the Door/Window Contact on the side of the window or the door. The ideal distance to the sensor is 3 mm. The sensor must be aligned with the window or the door.

For dark surfaces (e.g. brown window/door) you should place the reflecting sticker at the surface opposite the Door/Window Contact.

Note: After commissioning, the door/window contact requires 2-3 opening cycles to correctly detect the movement stroke.

6.6 Factory Reset

Press and hold the button in the housing of your Door/Window Contact for at least **10 seconds**. After successful reset, the red LED flashes twice and the green LED flashes three times.

Note: After the reset, the Door/Window Contact switches to commissioning mode without reinserting the batteries. Your primary Z-Wave controller will be informed about the performed reset. Use the factory reset only if your primary Z-Wave controller is no longer available or is inoperative for other reasons.

7. General Configuration

Parameter	Wert
Basic Device Attribute	0x07 – GENERIC_TYPE_SENSOR_NOTIFICATION
Specific Device Attribute	0x01 – SPECIFIC_TYPE_NOTIFICATION_SENSOR
Role Type	0x06 – ROLE_TYPE_SLAVE_SLEEPING_REPORTING
Icon Type	0x0C06 – ICON_TYPE_SPECIFIC_SENSOR_NOTIFICATION_ACCESS_CONTROL
User Icon Type	0x0C06 – ICON_TYPE_SPECIFIC_SENSOR_NOTIFICATION_ACCESS_CONTROL
Manufacturer Identifier	0x0148 – MFG_ID_EUROTRONICS
Product Type Identifier	0x0010
Product Identifier	0x0002
Firmware identifier	0x1002

8. Z-Wave

Command Class	Description	Version	Control (C) Support (S)	Security *
Association	Allows to associate with other Z-Wave devices.	2	S	U, S0, S2
Association Group Information	Allows to group associations.	1	S	U, S0, S2
Battery	Returns the current battery level of the device.	1	S	U, S0, S2
Device Reset Locally	Informs the Z-Wave Controller that the device was factory reset.	1	S	U, S0, S2
Firmware Update Meta Data	Allows Over the Air Update of the device.	4	S	U, S0, S2
Manufacturer Specific	Provides information about manufacturer and product.	2	S	U, S0, S2
Notification	Informs the controller about system events.	8	S	U, S0, S2
Power Level	Used to alter the rf-power (required by Z-Wave).	1	S	U, S0, S2
Security	Allows encrypted Z-Wave communication.	1	S	U
Security 2	Allows encrypted Z-Wave communication.	1	S	U

Supervision	Transmits Z-Wave Commands with an execution confirmation.	1	S	U
Transport Service	Handles the transmission of large telegrams.	2	S	U
Version	Returns information about the firmware.	2	S	U, S0, S2
Wake Up	Handles and wake-up notification.	2	S	U, S0, S2
Z-Wave Plus Info	Identifies the device as a Z-Wave Plus device.	2	S	U

* Availability of the Command Class after adding the Door/Window Contact Z-Wave Plus to your Z-Wave network.

U Unsecure

S0 Z-Wave Security Standard S0

S2 Z-Wave Security Standard S2

9. Association

Door/Window Contact Z-Wave Plus can be associated with other devices.

Group No.	Description	Commands	Max supported Nodes
1	Lifeline	BATTERY_REPORT NOTIFICATION_REPORT DEVICE_RESET_LOCALLY_NOTIFICATION	1
2	AN / AUS	BASIC_SET	5

10. Configuration

Door/Window Contact Z-Wave Plus does not have any configurable parameters.

11. Notification

Door/Window Sensor Z-Wave Plus will send notifications to the Z-Wave Controller.

Notification type	Reason	Description
Access Control	Door or window position changed.	Door/Window position 0x16: Door/Window opened 0x17: Door/Window closed

12. Help

Problem	Solution
The Door/Window Contact was already working and all of a sudden it doesn't work anymore.	<p>Restart your primary Z-Wave controller. If the door/window contact still does not respond afterwards, follow the steps below:</p> <ul style="list-style-type: none">- Remove your Door/Window Contact from your Z-Wave network (see 6.3 on page 8).- Reset your Door/Window Contact to factory settings (see 6.4 on page 8)- Add your Door/Window Contact to your Z-Wave network again
The Door/Window Contact was integrated into the Z-Wave network and false alarms occur from time to time.	<p>1.) The sensor works optically with light in the infrared range (IR). For reliable operation, the sensor must be mounted on a straight surface so that the sensors are at right angles to the base surface. Only in this way can the emitted light pulses be cleanly reflected and returned to the evaluation window of the sensor.</p> <p>2.) Check if the surface opposite the sensor surface from the Door/Window Contact is two-tone. If the seal is black and the window frame has a light aluminum, it is possible that the sensor is triggering a false alarm. If this is the case, tape the surface that is detected by the sensor with a reflective film that adheres well.</p> <p>Advice: The reflector strip supplied is often too small and the adhesion insufficient. Use masking tape or another reflective foil as an alternative. The masking tape or foil must not be black or have a very dark color.</p> <p>If a strong gust of wind blows against the window or you lean against the window and false alarms occur, the distance of the door/window contact is insufficient. We recommend a distance of 3 - 5 millimeters. Too tight installation (e.g. 1 mm) may lead to increased false alarms.</p> <p>Note: In principle, optical systems can be impaired by incident external radiation or special optical conditions (base surface too inclined, etc.). Unfortunately, these systems cannot be guaranteed to function cannot be guaranteed for every installation site. can be guaranteed for every installation location.</p>

13. Cleaning

NOTE: RISK OF DAMAGE!

Improper handling of the Door/Window Contact Z-Wave Plus can lead to damage.

- Do not immerse the Door/Window Contact Z-Wave Plus in water or other liquids.
- Do not use aggressive cleaning agents, brushes with metal or nylon bristles or sharp or metallic cleaning objects such as knives, hard spatulas and the like. These can damage the surfaces.
- Clean the Door/Window Contact Z-Wave Plus with a soft, dry cloth. For removal of heavy soiling, the cloth can be slightly moistened.

14. Technical Specifications

Device description	Door/Window Contact Z-Wave Plus	Method of operation	Type 1
EAN	4260012712056	Dimensions (WxHxD)	82x 24 x 21 mm
Article Number	700203	Weight	60 g (incl. battery)
Supply Voltage	CR123 A battery	Degree of protection	IP20
Radio Frequency	868,42 MHz	Degree of pollution	2
Output Power	+4dBm	Signalisation	LEDs
		Color	white

Technical modifications are subject to change. All descriptions for compatibility are without engagement.

15. Disposal

Advice on environmental protection:

 From the date of implementation of European guidelines 2012/19/EU into national law, the following applies: Electric and electronic devices and batteries may not be disposed of in household waste. The consumer is obliged to return electric and electronic devices and batteries to the public collection points established for them or to the point of sale. The particulars of this are regulated by the applicable state laws. The symbol on the product, operation instructions or packaging points to these provisions. You make an important contribution to the protection of the environment by reusing or recycling old equipment/batteries or making use of them in other ways.

 Dispose of the packaging sorted by type. Add paperboard and cardboard to the waste paper, foils to the recyclables collection. The symbols on the product, the instruction manual or the packaging refer to these regulations. By recycling, material utilisation or other forms of utilisation of old devices/batteries, you make an important contribution to the protection of our environment.

Declaration of conformity:

 Hereby, Eurotronic Technology GmbH declares that the Door/Window Contact Z-Wave Plus is in compliance with Directive 2014/53/EU. The full text of the EU declaration of conformity is available at the following internet address: <https://eurotronic.org/service/downloads/>.

16. Warranty

The 24-months warranty period begins at the day of purchase. Please keep the receipt as evidence of purchase. During the warranty period, defective radiator thermostats may be sent to your dealer or the address below. Please ensure sufficient postage is paid. A new or repaired device will then be sent to you free of charge. No new warranty period begins with the repair or replacement of the device.

After the warranty period has expired, you also have the option of sending the defective device to the specified address with sufficient postage for repair. Repairs after the warranty period have expired are subject to a charge. Your statutory rights are not limited by this warranty.

17. Support and Contact Information

If you wish to receive further technical support or information about other Eurotronic products, please contact us via E-Mail or telephone.

Eurotronic Technology GmbH
Südweg 1
36396 Steinau-Ulmbach
Deutschland

Telephone: +49 (0) 6667 91847-0
Email: info@eurotronic.org
Web: www.eurotronic.org